

YTS[®]
since 1966

PRODUCT GUIDE

AIR OPERATED
DOUBLE DIAPHRAGM
PUMPS

High Quality Japanese Products



Contents

1. Presenting YTS Double Diaphragm Pumps ..	2
2. Diaphragm Pump Capabilities	3
3. Diaphragm Pump Structure	4
4. Standard Models	
<i>D030 Pump Models (E/L Not Required)</i>	<i>5</i>
<i>D031 Pump Models (E/L Not Required)</i>	<i>6</i>
<i>D050 Pump Models</i>	<i>7</i>
<i>D051 Pump Models</i>	<i>8</i>
<i>D101 Pump Models</i>	<i>9</i>
<i>D152 Pump Models</i>	<i>10</i>
<i>D200 Plastic/Metallic Pump Models</i>	<i>11</i>
<i>D250 Plastic/Metallic Pump Models</i>	<i>12</i>
<i>D400 Plastic/Metallic Pump Models</i>	<i>13</i>
<i>D400-M Plastic/Metallic Pump Models</i>	<i>14</i>
<i>D500 Plastic/Metallic Pump Models</i>	<i>15</i>
<i>D500-M Plastic/Metallic Pump Models</i>	<i>16</i>
<i>D800 Plastic/Metallic Pump Models</i>	<i>17</i>
<i>D800-M Plastic/Metallic Pump Models</i>	<i>18</i>
<i>PTFE Pump TT Models</i>	<i>19</i>
<i>Virgin High Purity PTFE Pump HT Models</i>	<i>20</i>
<i>Flap Valve Solids Transfer Pump Models</i>	<i>21</i>
<i>Clamped Pump Models</i>	<i>22</i>
5. Specialty Pump Models	23
6. Pump Dimensional Drawings	26
7. Common Accessories & Options	31
8. Fully Engineered Diaphragm Pumps	33
9. Pump Model Code Nomenclature	34

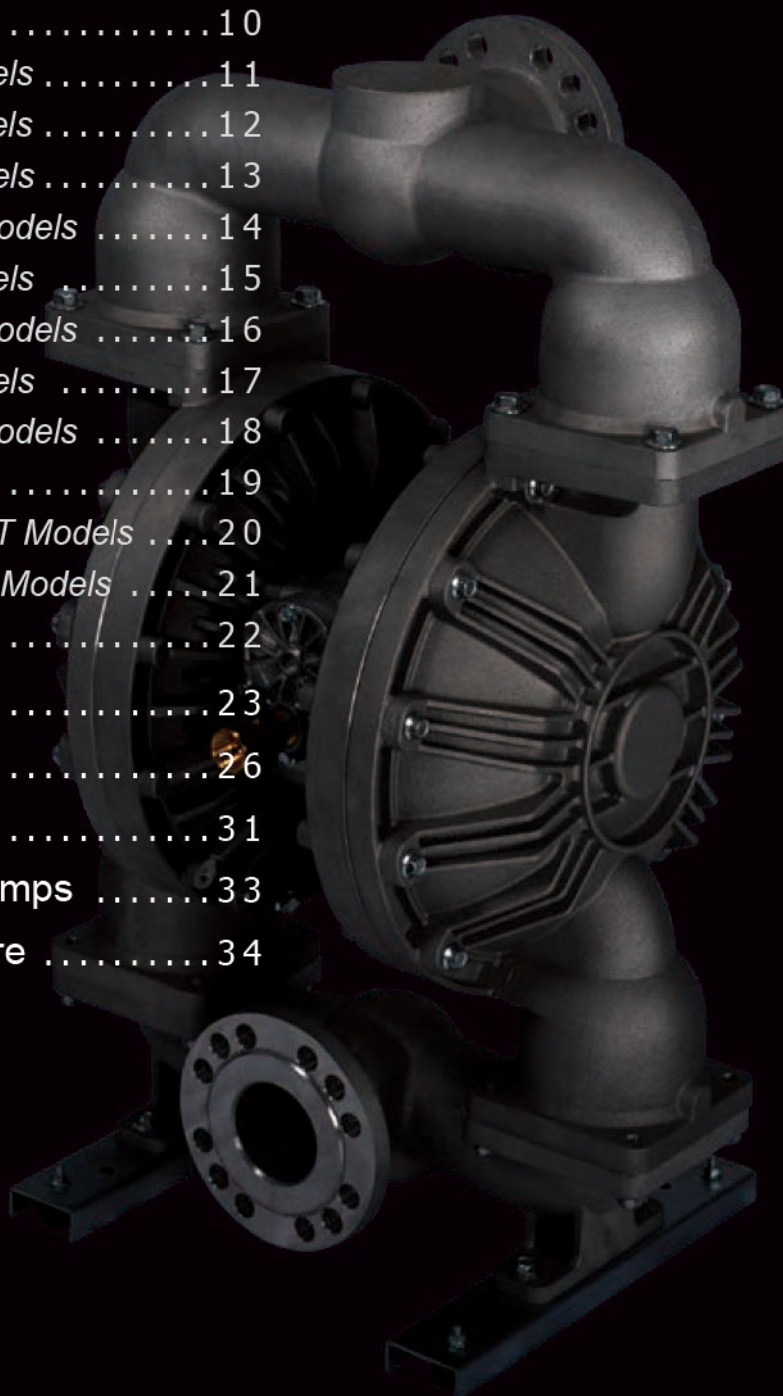

Presenting YTS Double Diaphragm Pumps

YTS has been producing a large range of Air Operated Double Diaphragm Pumps in Japan since 1978 and now offers a huge line-up of standard & customized pumps available in many different sizes & materials.

All YTS pumps are specifically designed to be used in process type liquid transfer applications and offer various engineered design features enabling efficient high performance liquid transfer & high operational reliability. They can be easily and quickly serviced and maintained even without pulling the pump from the process line. All serviceable wear components are modular and fully replaceable offering simple low cost replacement over a long lifetime of use.

Due to their engineered design, and due to the specific utilization of modern high tech materials, all YTS pumps can be operated without the need for Air Line Oil or Grease Lubricants. They therefore offer safe, clean zero emissions pump operation, protecting people, processes and work environments from dangerous airborne vaporized contaminants.

The new generation Looped C[®] Spool and the third generation Coil-Spring Air Valve offer much improved pumping performance, air consumption, operational reliability & reduced maintenance. Pumps fitted with the new patent pending Air EcoRing offer on average, 16% better air consumption figures without any negative effects to overall pumping performance.

All pumps incorporate independent high performance Pilot Valves for unrivalled reliability and high speed short stroke operation. YTS pumps utilize large diameter air porting and will resist stalling and resist freezing in nearly all conditions. They have leak resistant design features such as; fully bolted construction, machined liquid mating surfaces and registered fit body assembly. All YTS pumps are fully torqued and rigorously tested prior to shipment.



Diaphragm Pump Capabilities

Dry Run

Diaphragm Pumps can Run Dry for extended periods with no damage to the pumps moving parts. Also when running dry the pump will not overheat.

#1 Dry running pumps will speed up and will consume higher amounts of air.

#2 Dry Running can negatively affect the life of PTFE Diaphragms.

Transfer Solids

Due to their unique design, liquid slurries as well as large sized solids such as beads, stones etc. can be pumped with ease.

#1 the allowable solid size is different for each pump and is determined by the ball valve dimensions.

#2 Abrasive slurries can be pumped however care should be taken that the wetted materials of construction are abrasion resistant.

Variable Flow Rates and Discharge Pressure

By adjusting either the air regulator or a liquid discharge valve, it's possible to operate the pump anywhere between 0 liters per minute to full capacity. Liquid discharge pressure can be adjusted from less than 1 bar up to 8.4 bars, on some larger pumps.

Dead Head

A Diaphragm Pump can run against a semi closed or fully closed liquid discharge valve "Dead Head" without damage or wear to the pump. Therefore the Discharge Line may be closed fully at any time and even closed repeatedly. There will be no Power consumed, no Temperature increase and no damage to the pump, it will simply stop.

#1 Discharge Pressure cannot exceed Air Pressure so there is no need for a Pressure Relief System.

Self-priming

Diaphragm Pumps can operate dry and they also generate relatively high Vacuum Pressure, thus allowing the pump to Self-Prime.

#1 There is no need to use special mechanisms, equipment or special startup procedures to prime the pump.

#2 Pumps can operate both wet and dry and can self-prime repeatedly without damage.

Safety Transfer Flammable Materials

Diaphragm pumps are operated by compressed air and do not have any kind of electrical connections. They cannot overheat and they are cooled naturally during operation by the supply of compressed air. When correctly earthed, they are considered safe to use when pumping flammable liquids or when used in Explosive Environments.

Made in Japan

All YTS Pumps are designed engineered and manufactured in Japan. Every pump is torqued and tested prior to dispatch to ensure correct performance and optimal leak proof operation.

The Looped C[®] Spool

The new Looped C[®] Spool offers improved switching reliability and longer parts life expectancy. The Looped C[®] Spool has fully replaceable Seal Rings and a new lightweight Shaft. The Sleeve has been redesigned offering increased wear resistance and increased surface smoothness. Spool & Sleeve are both outside accessible and completely Non-lubricated.



The Air EcoRing

When installed can decrease actual Air Volume requirements by up to 25% with no decrease in liquid low rates. (Compared to an old equivalent model pump. (Average 16%).



NEW Threaded Flange Manifolds

The manifolds for the type 400,500 and 800 standard metallic pumps are modified to the newly designed "threaded flange manifolds". This provides customers a wider option of both flange and thread connection availability.

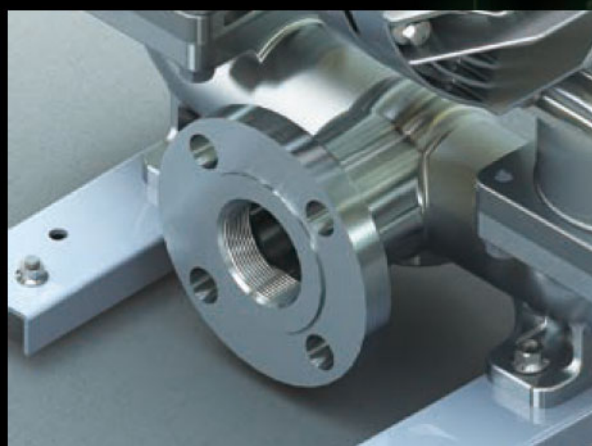

Diaphragm Pump Structure

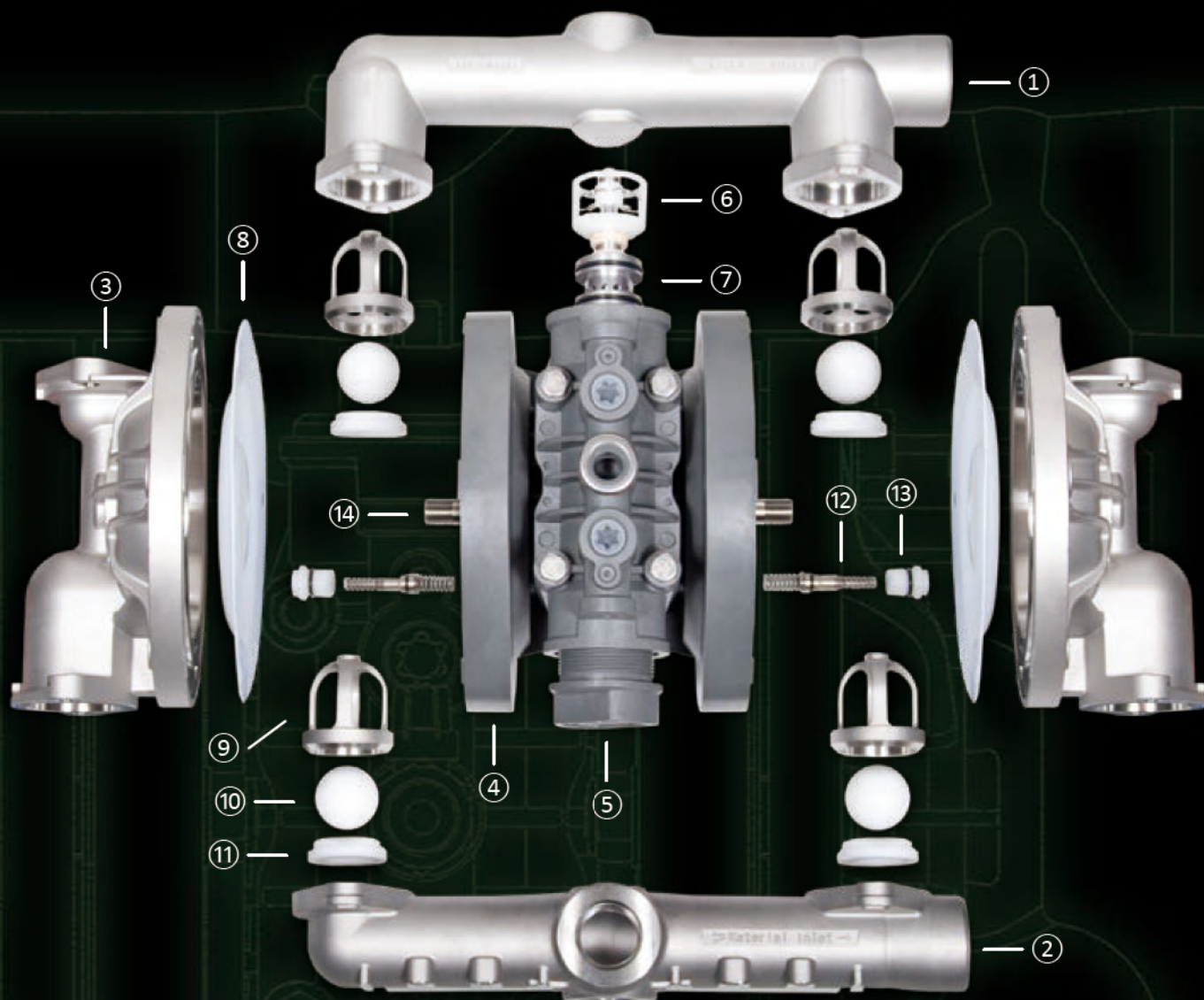

① Out Manifold

② In Manifold

③ Out Chamber

④ Body Assembly

⑤ Main Valve Assembly

⑥ C Spool Assembly (Looped C®)

⑦ Sleeve Assembly

⑧ Diaphragm

⑨ Valve Stopper

⑩ Ball Valve

⑪ Valve Seat

⑫ Pilot Valve Assembly

⑬ Pilot Valve Seat

⑭ Center Rod

D030 Pump Models (E/L Not Required)

Diaphragm Pumps with 1/4" Connections

8.5 L/min Max Flow Rate.

An Export Licence is not required.



Some Models



D030V

D030HT

Type 030		
Model Code	030 V T	030 H T
Max Flow Rate	8 L/min	8.5 L/min
Connection Type	Thread	
Connection Size	Air Supply	1/4"
	Air Exhaust	3/8"
	Liquid	1/4" * Side Port
Check Valve Type	Flat	
Max Solid Size	0mm	
Supply Air Pressure Range	0.2 ~ 0.7MPa	0.2 ~ 0.5MPa
Materials	Wetted Body	CFPVDF
	Air Motor	PPS
	Diaphragm	PTFE

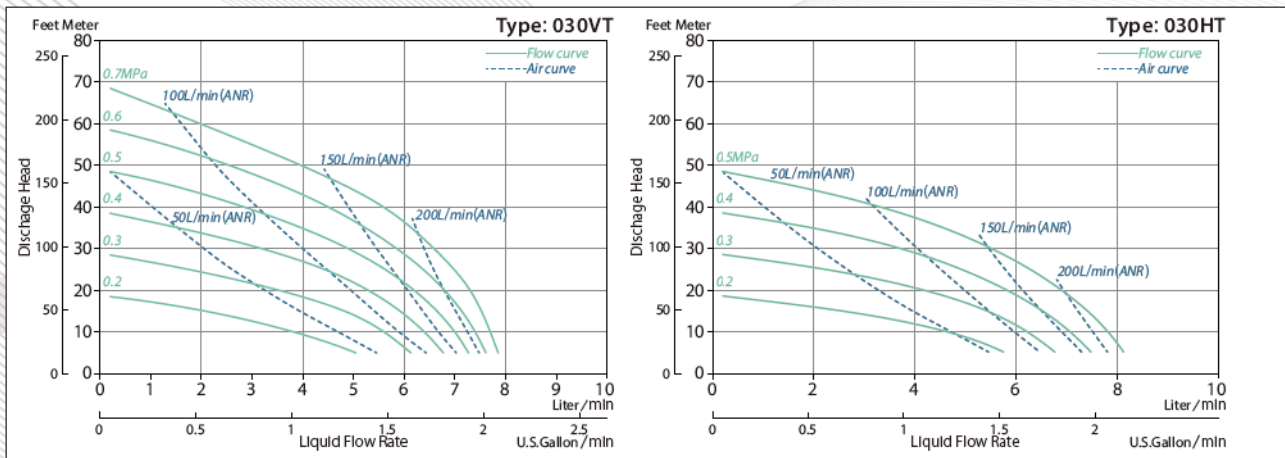

NEW

D031 Pump Models (E/L Not Required)

Diaphragm Pumps with 1/4" Connections

8.5 L/min Max Flow Rate.

An Export Licence is not required.



Some Models



D031V

D031TT

Type 031		
Model Code	031 V T	031 T T
Max Flow Rate	8 L/min	8.5 L/min
Connection Type	Thread	
Connection Size	Air Supply	1/4"
	Air Exhaust	-
	Liquid	1/4" * Side Port
Check Valve Type	Flat	
Max Solid Size	0mm	
Supply Air Pressure Range	0.2 ~ 0.7MPa	0.2 ~ 0.5MPa
Materials	Wetted Body	CFPVDF
	Air Motor	PPG
	Diaphragm	PTFE

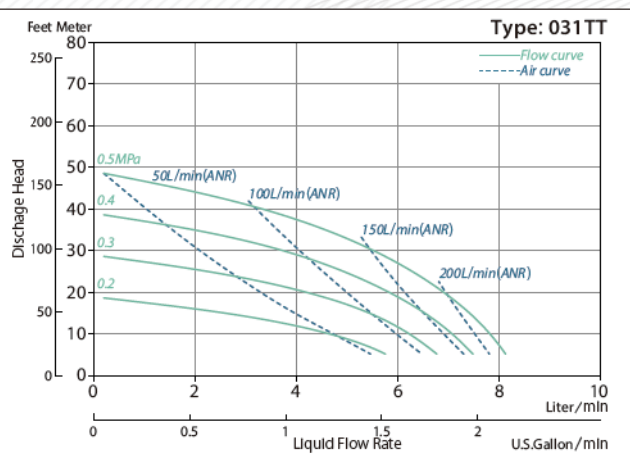
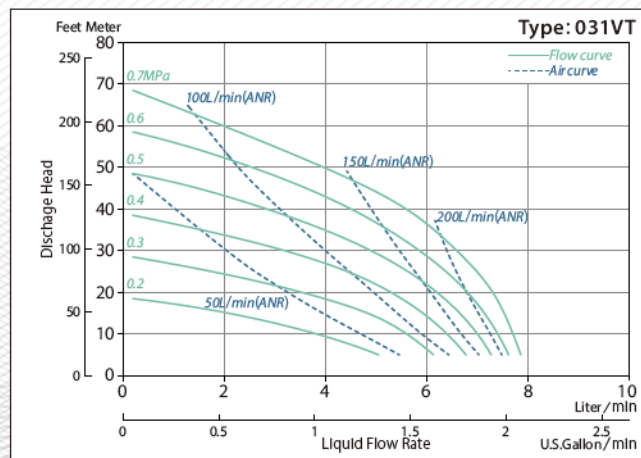

D050 Pump Models

Diaphragm Pumps with 1/4" Connections
11.5 L/min Max Flow Rate.



Some Models



D050P

D050A

Optional MultiPort Models.

Type 050		
Model Code	050 P · V T 050 A · S T	
Max Flow Rate	11.5 L/min	
Connection Type	Thread	
Connection Size	Air Supply	1/4"
	Air Exhaust	3/8"
	Liquid	1/4" * Side Port (Multiport Option)
Check Valve Type	Flat	
Max Solid Size	0mm	
Supply Air Pressure Range	0.2 ~ 0.7MPa	
Materials	Wetted Body	PP, CFPVDF (PPG, CFPP) Aluminium, SUS
	Air Motor	PPS
	Diaphragm	PTFE

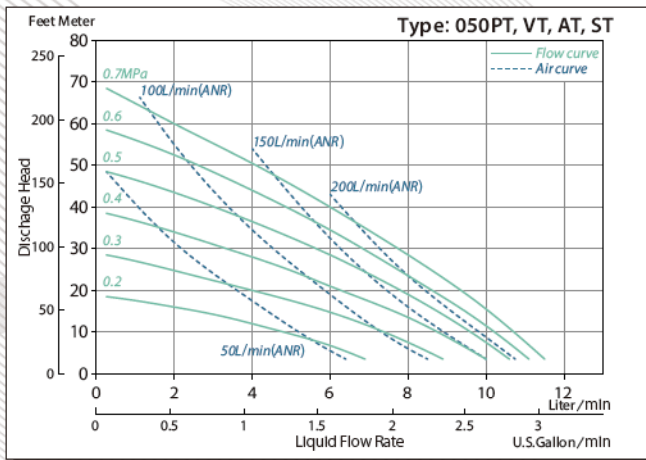

NEW D051 Pump Models

Diaphragm Pumps with 1/4" Connections
15 L/min Max Flow Rate.



Some Models



D051P



D051S



Optional MultiPort Models.

Type 051		
Model Code	051 P · V T	
Max Flow Rate	15 L/min	
Connection Type	Thread	
Connection Size	Air Supply	1/4"
	Air Exhaust	-
	Liquid	1/4" ※ Side Port (Multiport Option)
Check Valve Type	Flat	
Max Solid Size	0mm	
Supply Air Pressure Range	0.2 ~ 0.7MPa	
Materials	Wetted Body	PP, CFPVDF (PPG, CFPP) Aluminium, SUS
	Air Motor	PPG
	Diaphragm	PTFE

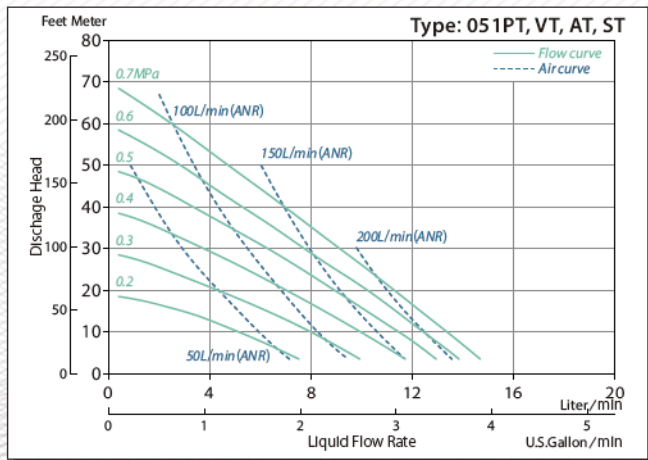

D101 Pump Models

Diaphragm Pumps with $\frac{3}{8}$ " Connections
24 L/min Max Flow Rate.



D101A



D101P



Optional $\frac{1}{2}$ " Connections.

Type 101		
Model Code	101 P □	101 A · S □
Max Flow Rate	22 L/min	24 L/min
Connection Type	Thread	
Connection Size	Air Supply	$\frac{1}{4}$ "
	Air Exhaust	$\frac{3}{8}$ "
	Liquid	$\frac{3}{8}$ " ($\frac{1}{2}$ " Option) ※ Multiport
Check Valve Type	Ball	
Max Solid Size	1mm or less	
Supply Air Pressure Range	0.2 ~ 0.7MPa	
Materials	Wetted Body	PP (PPG, CFPP) Aluminium, SUS
	Air Motor	Aluminium
	Diaphragm	CR, NBR, PTFE, TPEE, TPO

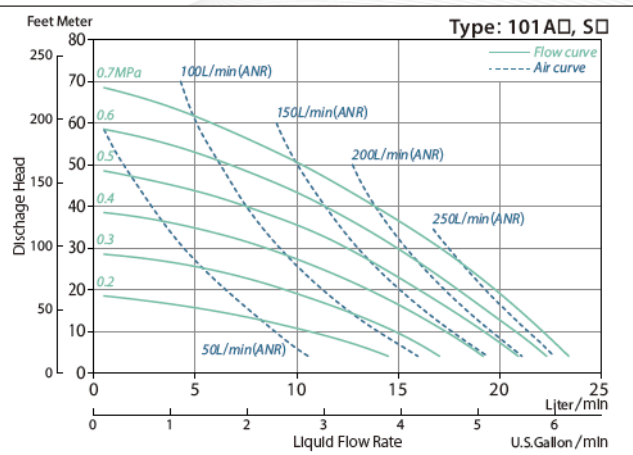
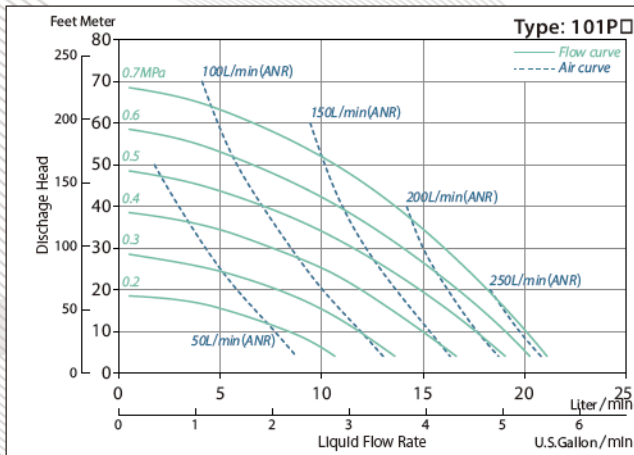

D152 Pump Models

Diaphragm Pumps with 1/2" Connections
65 L/min Max Flow Rate.



Some Models



D152P



D152A

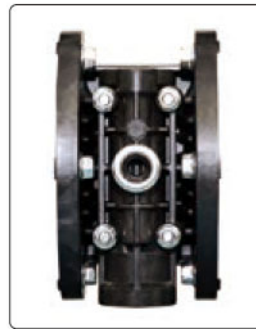

Optional Conductive PP
Air Motor Section

Type 152		
Model Code	152 P · V □	152 A · S □
Max Flow Rate	62 L/min	65 L/min
Connection Type	Thread	
Connection Size	Air Supply	1/4"
	Air Exhaust	3/8"
	Liquid	1/2" ※ Multiport
Check Valve Type	Flat	Ball
Max Solid Size	0mm	1mm or less
Supply Air Pressure Range	0.2 ~ 0.7MPa	
Materials	Wetted Body	PP, CFPVDF (CFPP) Aluminium, SUS
	Air Motor	PPG (CFPP)
	Diaphragm	CR, NBR, PTFE, TPEE, TPO

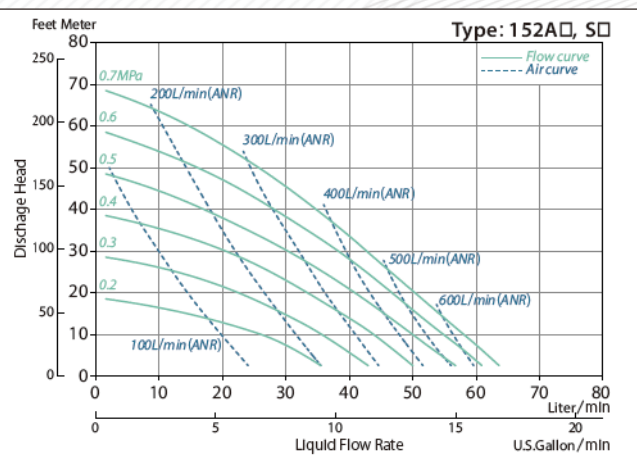
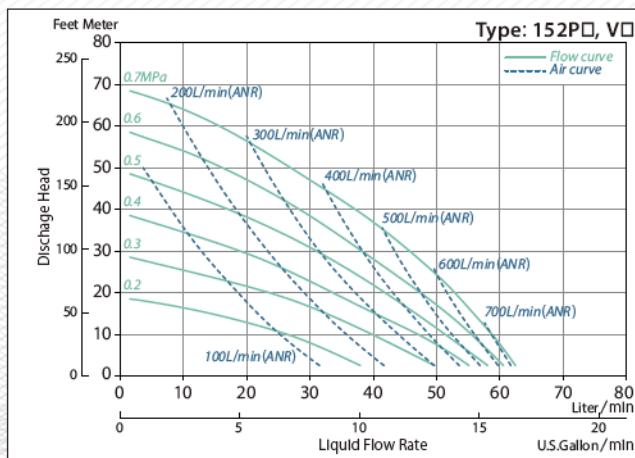

D200 Plastic / Metallic Pump Models

Diaphragm Pumps with 3/4" Connections
210 L/min Max Flow Rate.



Some Models

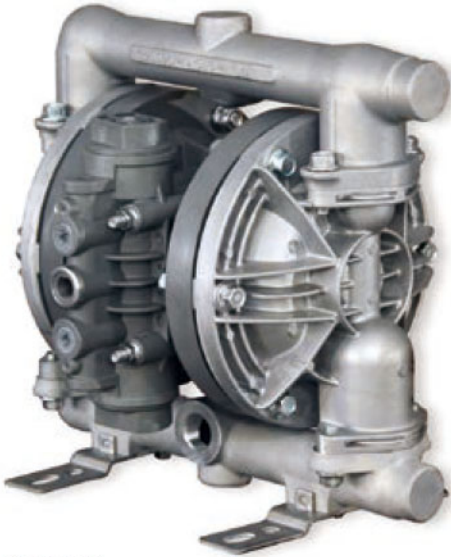

D200A



D200G□J



Optional Aluminium Air Motor Section



Optional Conductive PP Air Motor Section

Type 200

Model Code	200 G □	200 G T	200 A · S □	200 A · S T
Max Flow Rate	130 L/min	110 L/min	210 L/min	190 L/min
Connection Type	Thread or Flange		Thread	
Connection Size	Air Supply	1/4"		3/8"
	Air Exhaust	3/4"		
	Liquid	3/4" or 20A *Side Port		3/4" *Center Port
Check Valve Type	Ball			
Max Solid Size	2mm or less		6.5mm or less	
Supply Air Pressure Range	0.2 ~ 0.7MPa			
Materials	Wetted Body	PPG (CFPVDF)		Aluminium, SUS
	Air Motor	PPG		
	Diaphragm	CR, NBR, EPDM, FKM, TPEE, TPO	PTFE	CR, NBR, EPDM, FKM, TPEE, TPO

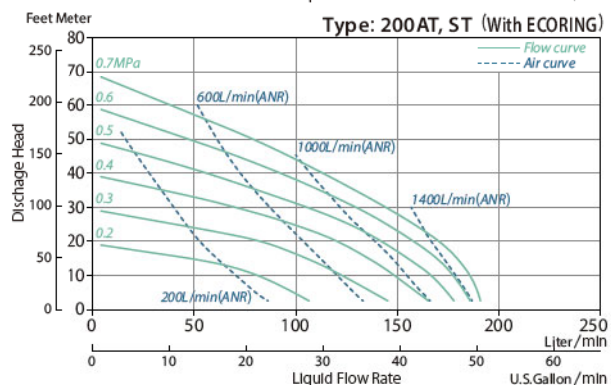
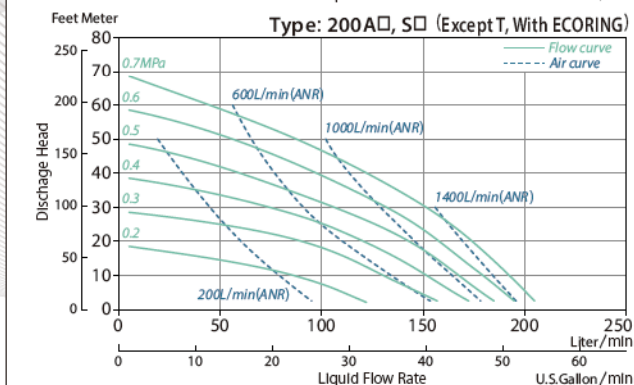
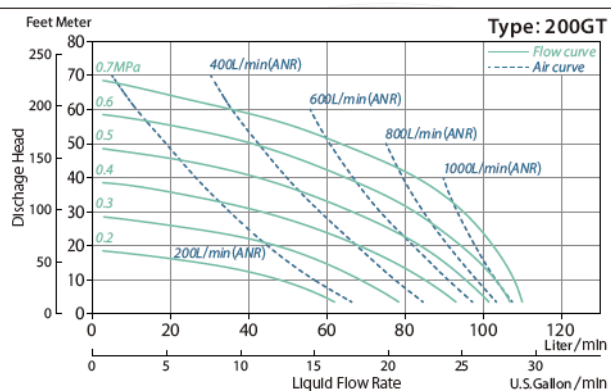
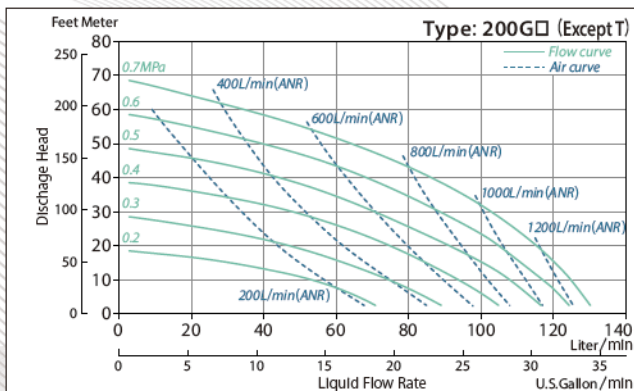

D250 Plastic / Metallic Pump Models

Diaphragm Pumps with 1" Connections
220 L/min Max Flow Rate.



Some Models



D250S



D250V□



Optional 1 1/2" Connections



Optional Aluminium Air Motor Section



Optional Conductive PP Air Motor Section

Type 250			
Model Code	250 G · V □		250 A · S □
Max Flow Rate	180 L/min		220 L/min
Connection Type	Thread or Flange		Thread
Connection Size	Air Supply	3/8"	
	Air Exhaust	3/4"	
	Liquid	1" or 25A ※Side Port	1" (1/2" Option) ※Multiport
Check Valve Type	Ball		
Max Solid Size	3mm or less		6.5mm or less
Supply Air Pressure Range	0.2 ~ 0.7MPa		
Materials	Wetted Body	PPG, CFPVDF (CFPP)	Aluminium, SUS (Cast Iron)
	Air Motor	PPG (Aluminium, CFPP)	
	Diaphragm	CR, NBR, EPDM, FKM, PTFE, TPEE, TPO	CR, NBR, EPDM, FKM, TPEE, TPO
			PTFE

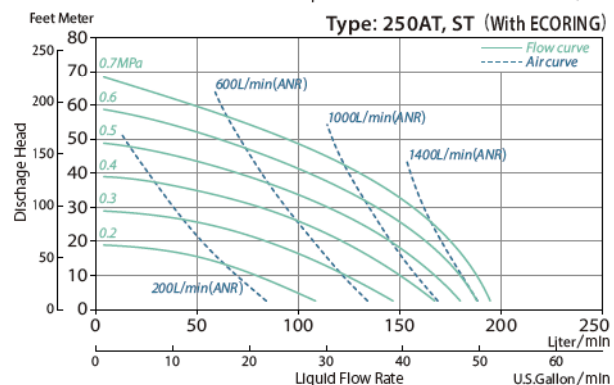
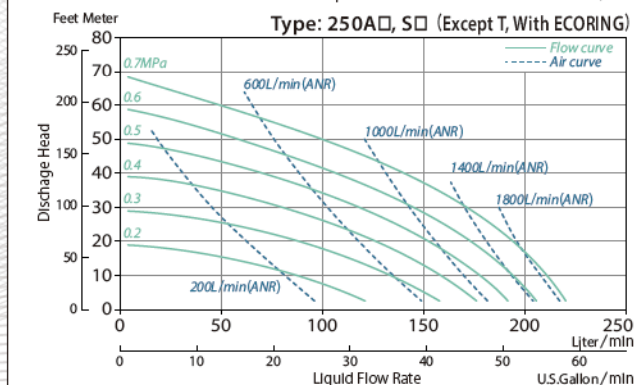
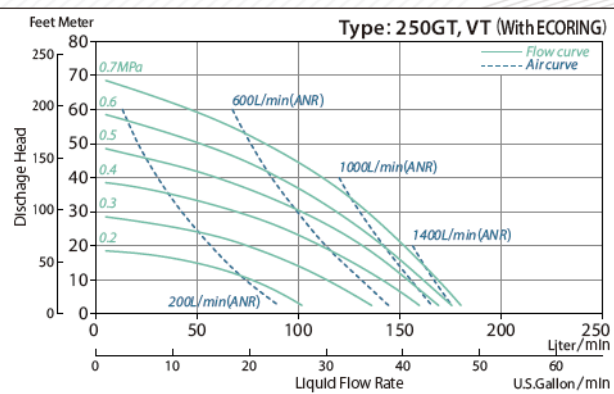
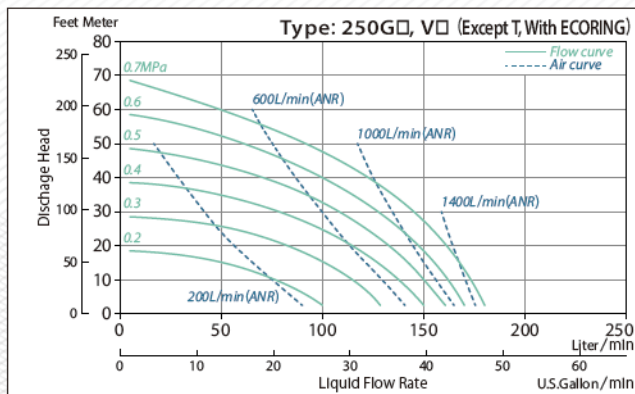

D400 Plastic / Metallic Pump Models

Diaphragm Pumps with 1½" Connections

600 L/min Max Flow Rate.

Fitted with the Looped C Air spool.



Some Models



D400G□J



D400V□J



D400A□J



D400S□J

Type 400

Model Code	400 G · V □	400 G · V T	400 A · S □	400 A · S T
Max Flow Rate	400 L/min	380 L/min	600 L/min	460 L/min
Connection Type	Flange		Threaded Flange	
Connection Size	Air Supply	¾"		
	Air Exhaust	1"		
	Liquid	40A ※Center Port	1½" or 40A ※Center Port	
Check Valve Type	Ball			
Max Solid Size	7mm or less		8mm or less	
Supply Air Pressure Range	0.2 ~ 0.7MPa		0.2 ~ 0.85MPa	0.2 ~ 0.7MPa
Materials	Wetted Body	PPG, CFPVDF (CFPP)		Aluminium, SUS (Cast Iron)
	Air Motor	Aluminium		
	Diaphragm	CR, NBR, EPDM, FKM, TPEE, TPO	PTFE	CR, NBR, EPDM, FKM, TPEE, TPO

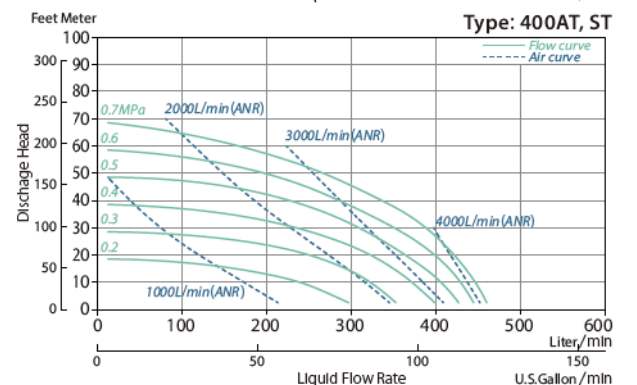
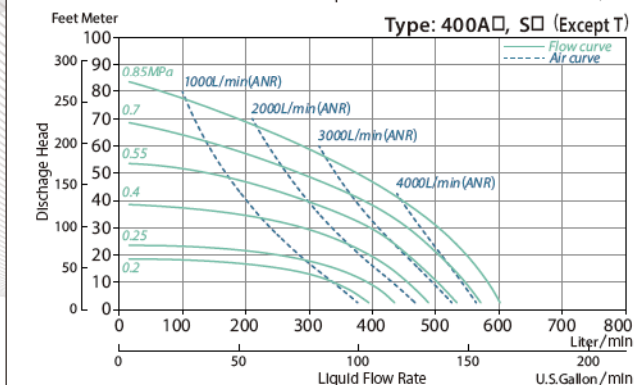
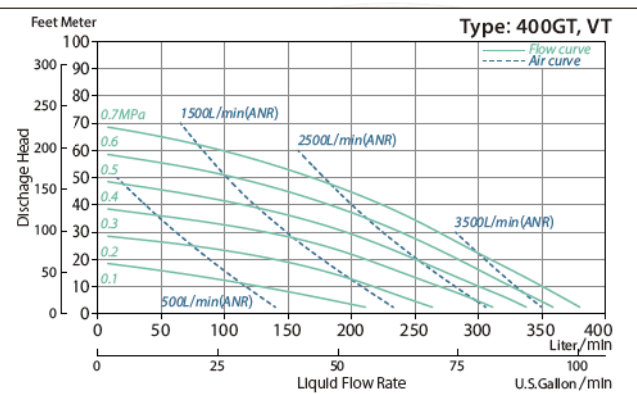
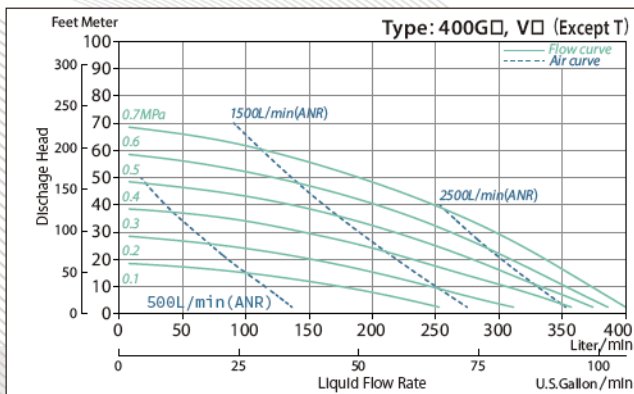

D400-M Plastic / Metallic Pump Models

Diaphragm Pumps with 1½" Connections

450 L/min Max Flow Rate.

Fitted with the heavy-duty mechanical coil-spring air motor.

Mechanical HD Spool



Some Models

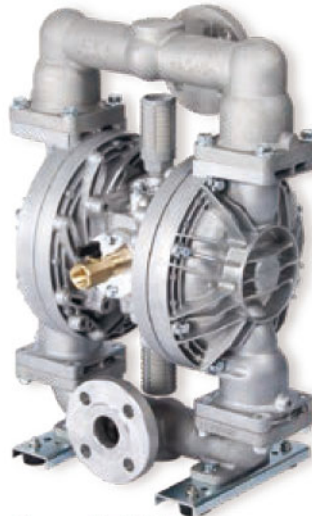

D400G□J-M

D400V□J-M

D400A□J-M

D400S□J-M

Type 400-M

Model Code	400 G · V □	400 G · V T	400 A · S □	400 A · S T
Max Flow Rate	390 L/min	360 L/min	450 L/min	400 L/min
Connection Type	Flange		Threaded Flange	
Connection Size	Air Supply		¾"	
	Air Exhaust		¾" ※2 Ports	
	Liquid		1½" or 40A ※Center Port	
Check Valve Type	Ball			
Max Solid Size	7mm or less		8mm or less	
Supply Air Pressure Range	0.1 ~ 0.7MPa	0.15 ~ 0.7MPa	0.1 ~ 0.85MPa	0.15 ~ 0.7MPa
Materials	Wetted Body		Aluminium, SUS (Cast Iron)	
	Air Motor		Aluminium	
	Diaphragm		CR, NBR, EPDM, FKM, TPEE, TPO	PTFE

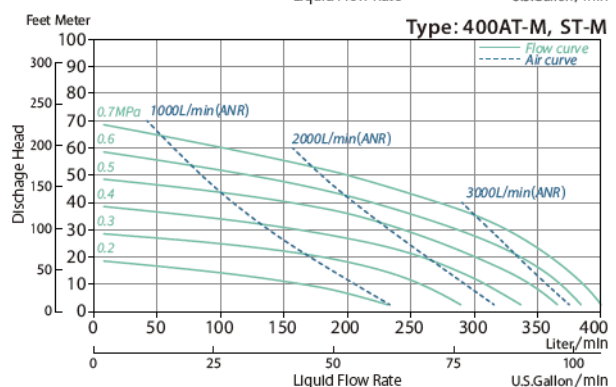
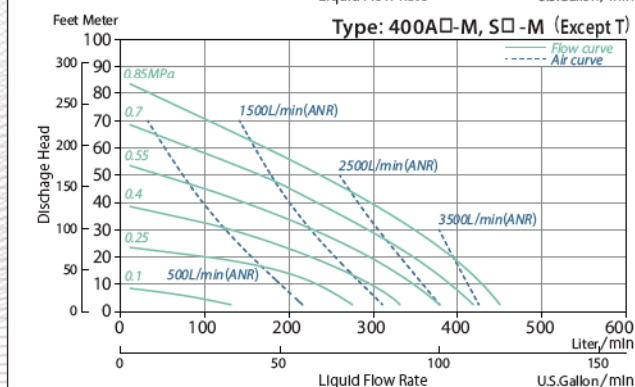
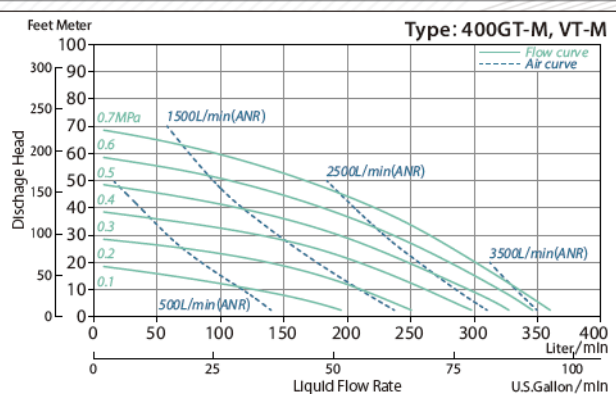
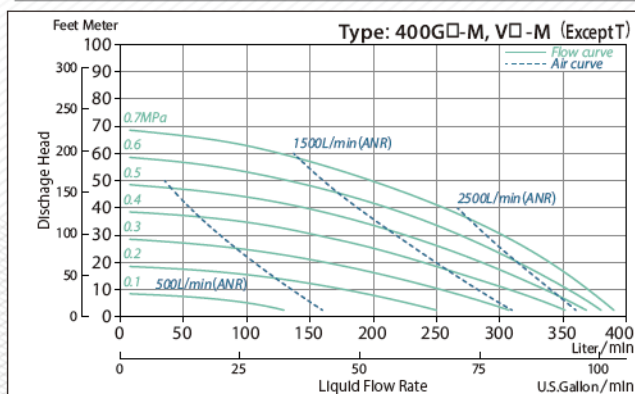

D500 Plastic / Metallic Pump Models

Diaphragm Pumps with 2" Connections

800 L/min Max Flow Rate.

Fitted with the Looped C Air spool.



Some Models



D500G□J



D500V□J



D500A□J



D500S□J

Type 500

Model Code	500 G · V □	500 G · V T	500 A · S □	500 A · S T
Max Flow Rate	650 L/min	600 L/min	800 L/min	600 L/min
Connection Type	Flange		Threaded Flange	
Connection Size	Air Supply	3/4"		
	Air Exhaust	1"		
	Liquid	50A ※Center Port	2" or 50A ※Center Port	
Check Valve Type	Ball			
Max Solid Size	8mm or less			
Supply Air Pressure Range	0.2 ~ 0.7MPa		0.2 ~ 0.85MPa	0.2 ~ 0.7MPa
Materials	Wetted Body	PPG, CFPVDF (CFPP)		Aluminium, SUS (Cast Iron)
	Air Motor	Aluminium		
	Diaphragm	CR, NBR, EPDM, FKM, TPEE, TPO	PTFE	CR, NBR, EPDM, FKM, TPEE, TPO

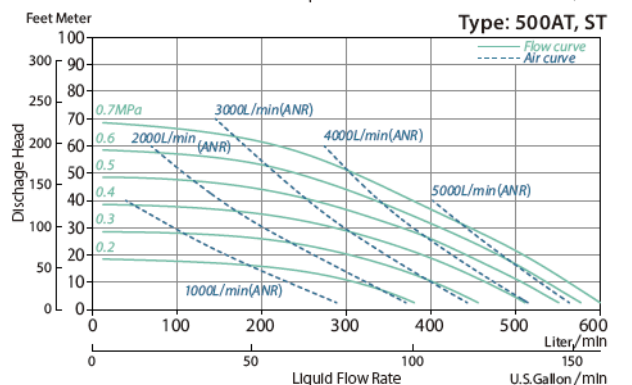
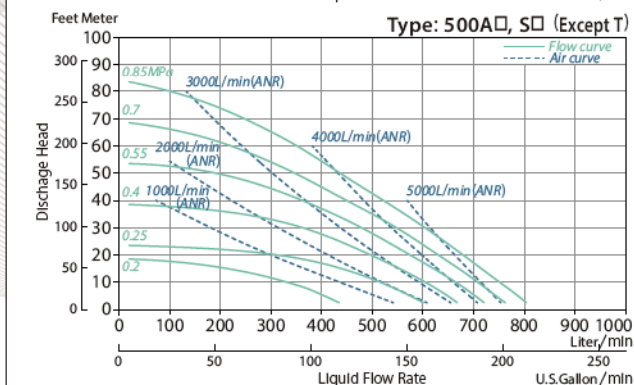
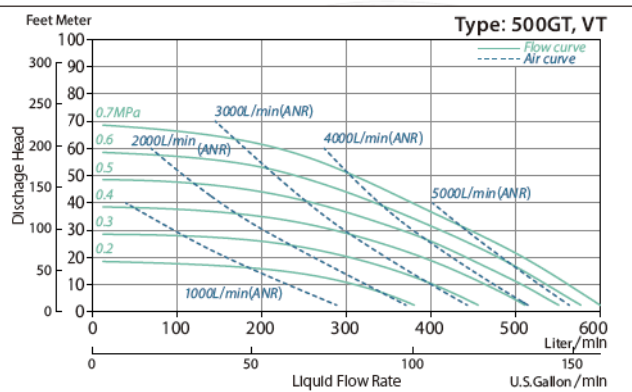
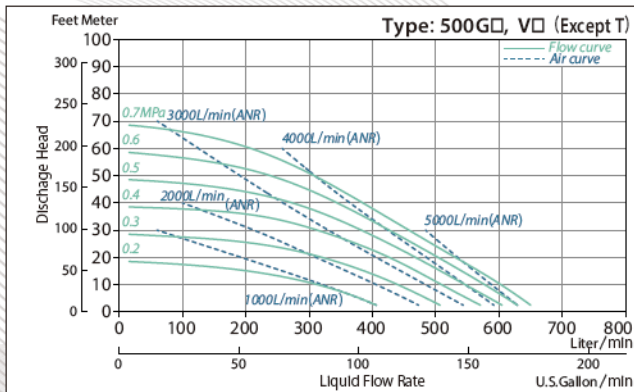

D500-M Plastic / Metallic Pump Models

Diaphragm Pumps with 2" Connections

750 L/min Max Flow Rate.

Fitted with the heavy-duty mechanical coil-spring air motor.

Mechanical HD Spool



Some Models

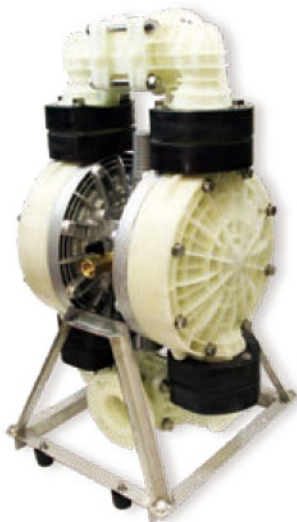

D500G□J-M



D500V□J-M



D500A□J-M



D500S□J-M

Type 500-M

Model Code	500 G · V □	500 G · V T	500 A · S □	500 A · S T
Max Flow Rate	640 L/min	520 L/min	750 L/min	520 L/min
Connection Type	Flange		Threaded Flange	
Connection Size	Air Supply	3/4"		
	Air Exhaust	3/4" ※2 Ports		
	Liquid	50A ※Center Port	2" or 50A ※Center Port	
Check Valve Type	Ball			
Max Solid Size	8mm or less			
Supply Air Pressure Range	0.1 ~ 0.7MPa	0.15 ~ 0.7MPa	0.1 ~ 0.85MPa	0.15 ~ 0.7MPa
Materials	Wetted Body	PPG, CFPVDF (CFPP)		Aluminium, SUS (Cast Iron)
	Air Motor	Aluminium		
	Diaphragm	CR, NBR, EPDM, FKM, TPEE, TPO	PTFE	CR, NBR, EPDM, FKM, TPEE, TPO

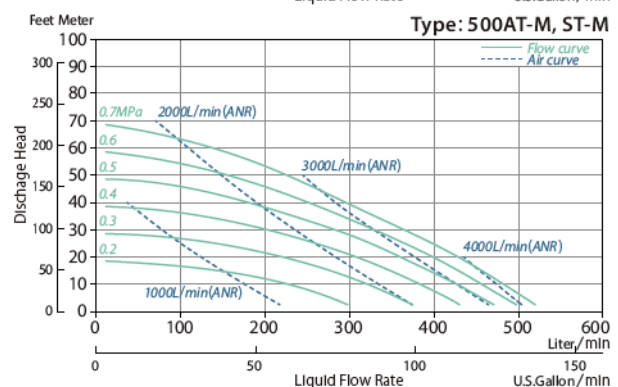
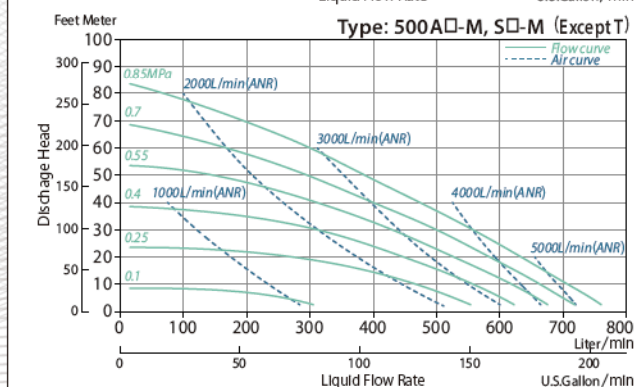
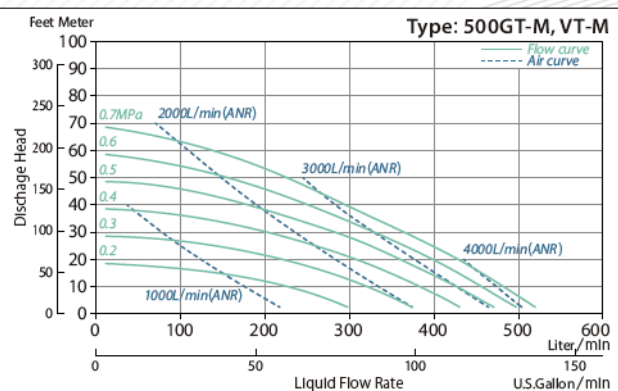
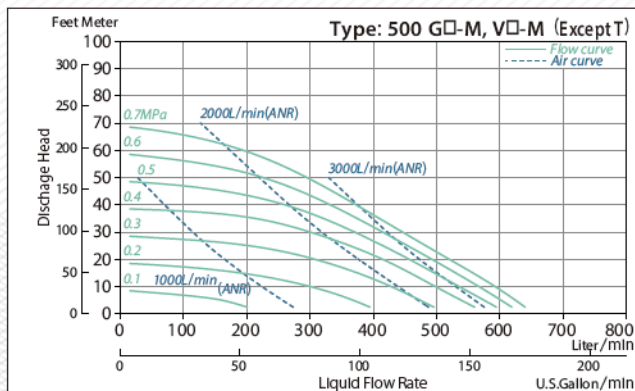

D800 Plastic / Metallic Pump Models

Diaphragm Pumps with 3" Connections

1050 L/min Max Flow Rate.

Fitted with the Looped C Air spool.



Some Models

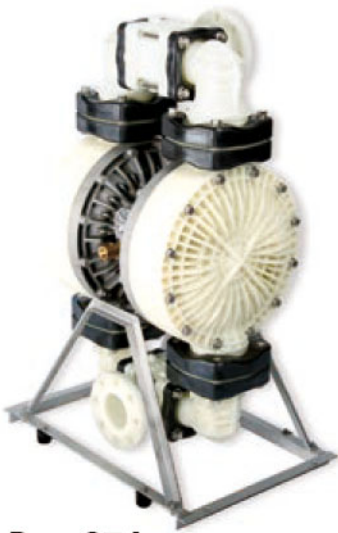

D800G□J



D800A□J



D800\$□J

Type 800

Model Code		800 G □	800 G T	800 A · S □	800 A · S T
Max Flow Rate		860 L/min	700 L/min	1050 L/min	700 L/min
Connection Type		Flange		Threaded Flange	
Connection Size	Air Supply	3/4"			
	Air Exhaust	1"			
	Liquid	80A ※Center Port		3" or 80A ※Center Port	
Check Valve Type		Ball			
Max Solid Size		10mm or less			
Supply Air Pressure Range		0.2 ~ 0.7MPa		0.2 ~ 0.85MPa	0.2 ~ 0.7MPa
Materials	Wetted Body	PPG		Aluminium, SUS (Cast Iron)	
	Air Motor	Aluminium			
	Diaphragm	CR, NBR, EPDM, FKM, TPEE, TPO	PTFE	CR, NBR, EPDM, FKM, TPEE, TPO	PTFE

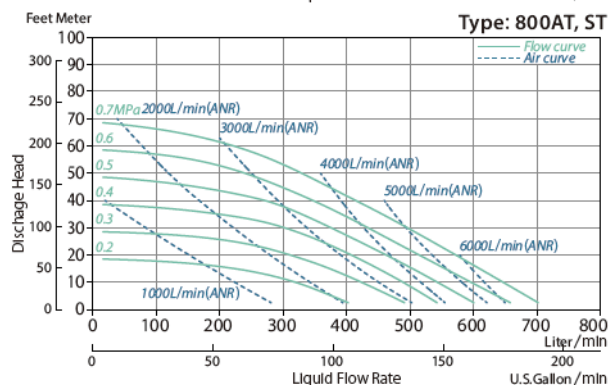
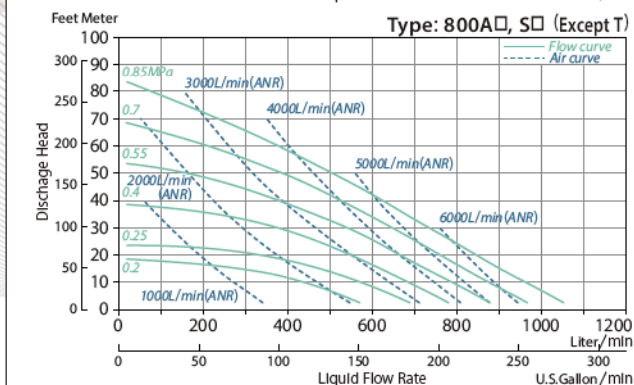
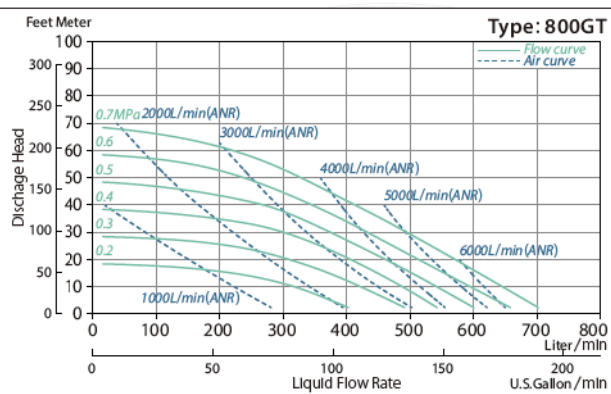
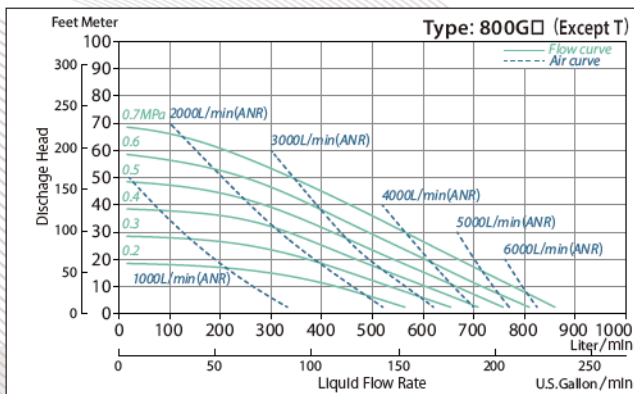

D800-M Plastic / Metallic Pump Models

Diaphragm Pumps with 3" Connections

850 L/min Max Flow Rate.

Fitted with the heavy-duty mechanical coil-spring air motor.

Mechanical HD Spool



Some Models



D800G□J-M



D800A□J-M



D800\$□J-M

Type 800-M

Model Code		800 G □	800 G T	800 A · S □	800 A · S T
Max Flow Rate		800 L/min	640 L/min	850 L/min	640 L/min
Connection Type		Flange		Threaded Flange	
Connection Size	Air Supply	3/4"			
	Air Exhaust	3/4" ※2 Ports			
	Liquid	80A ※Center Port		3" or 80A ※Center Port	
Check Valve Type		Ball			
Max Solid Size		10mm or less			
Supply Air Pressure Range		0.1 ~ 0.7MPa	0.15 ~ 0.7MPa	0.1 ~ 0.85MPa	0.15 ~ 0.7MPa
Materials	Wetted Body	PPG		Aluminium, SUS (Cast Iron)	
	Air Motor	Aluminium			
	Diaphragm	CR, NBR, EPDM, FKM, TPEE, TPO	PTFE	CR, NBR, EPDM, FKM, TPEE, TPO	PTFE

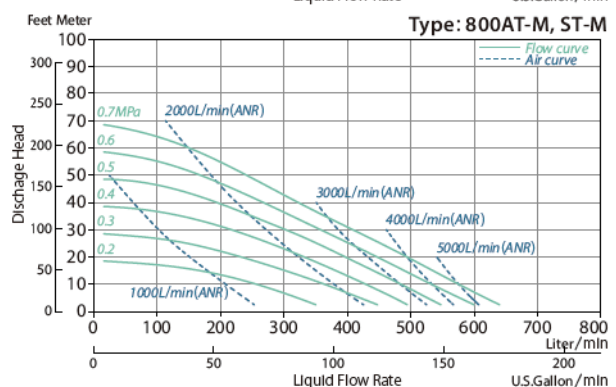
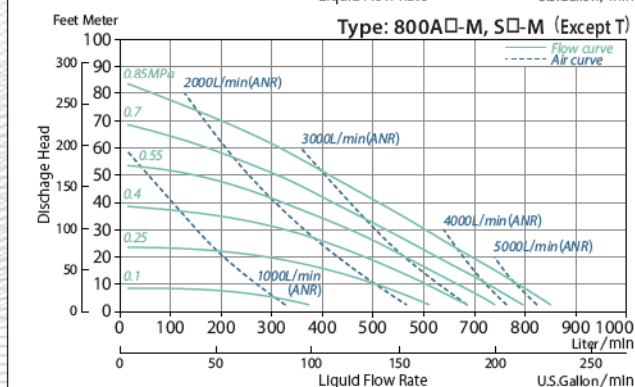
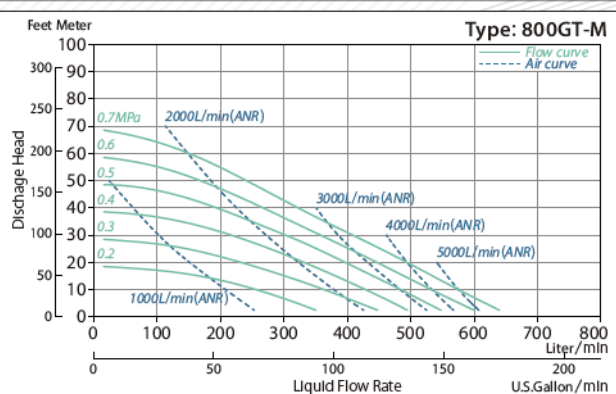
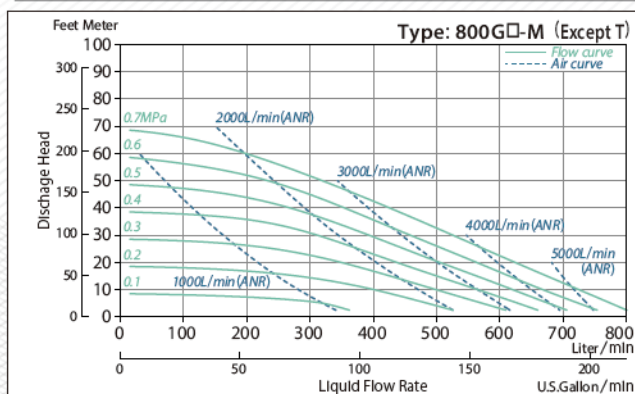

PTFE Pump TT Models

Diaphragm Pumps with 1/4" 1/2" & 1" Connections
Up to 150 L/min Max Flow rate.

Industrial Grade PTFE Pumps available in two different sizes.

*An Export Licence is not required for D031TT



D031TT



D051TT



D152TTJ



D250TTJ

Standard PTFE Pumps

Model Code	031 TT	051 TT	152 TT	250 TT
Max Flow Rate	8.5 L/min	11 L/min	50 L/min	150 L/min
Connection Type	Thread		Flange (Thread)	
Connection Size	Air Supply	1/4"		3/8"
	Air Exhaust	-		3/8"
	Liquid	1/4" ※SidePort		25A (1" Thread Option) ※Side Port
Check Valve Type	Flat		Ball	
Max Solid Size	0mm		2mm or less	3mm or less
Supply Air Pressure Range	0.2 ~ 0.5MPa			
Materials	Wetted Body	PTFE (CFPTFE)		
	Air Motor	PPG		PPG (CFPP)
	Diaphragm	PTFE		

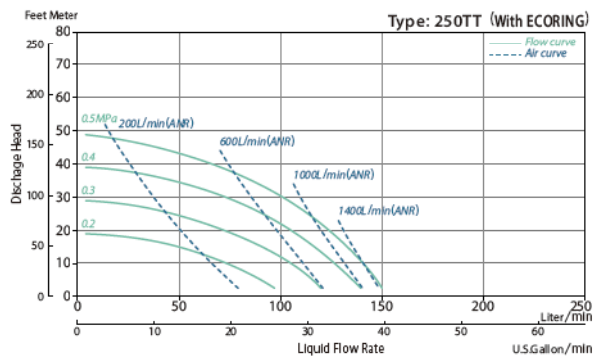
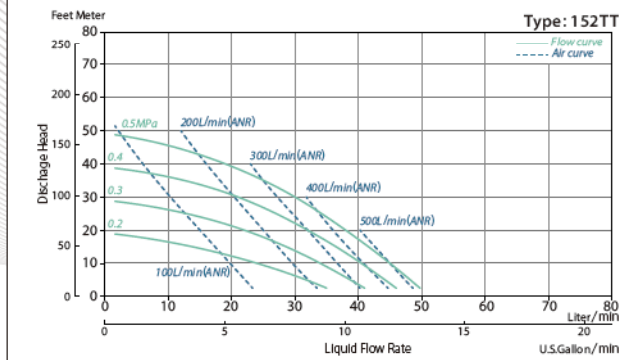
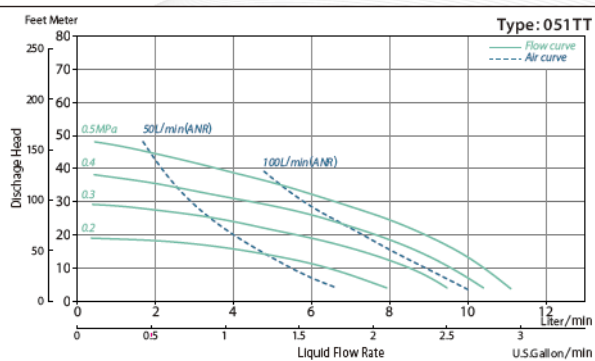
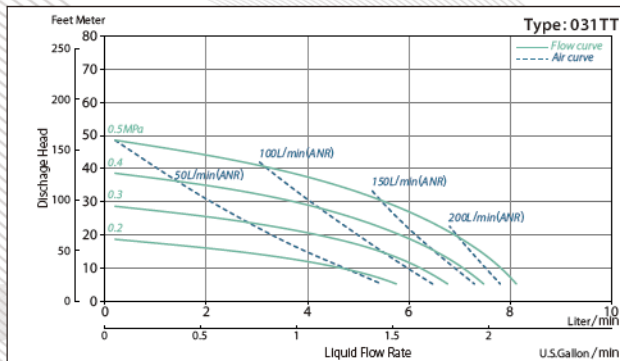

Virgin High Purity PTFE Pump HT Models

Diaphragm Pumps with 1/4" 3/8" 3/4" & 1" Connections
Up to 95 L/min Max Flow rate.

High Purity Virgin PTFE Pumps available in six different sizes.

*An Export Licence is not required for D030HT



High Purity PTFE Pumps						
Model Code	030 HT	050 HT	100 HT	200 HT	250 HT	400 HT
Max Flow Rate	8.5 L/min	11 L/min	27 L/min	54 L/min	64 L/min	95 L/min
Connection Type	Thread		Thread or Flange		Flange (Thread)	
Connection Size	Air Supply	1/4"		3/8"	1/2"	
	Air Exhaust	3/8"		3/4"		
	Liquid	1/4" *SidePort	3/8" or 10A *Side Port	3/4" or 20A *Side Port	25A (1" Thread Option) *Side Port	
Check Valve Type	Flat		Ball (Flat)			
Max Solid Size	0mm		1mm or less	2mm or less	3mm or less	
Supply Air Pressure Range	0.2 ~ 0.5MPa				0.2 ~ 0.7MPa	
Materials	Wetted Body	PTFE (CFPTFE)		PTFE		
	Air Motor	PPS		PP		HDPE / PP
	Diaphragm	PTFE				

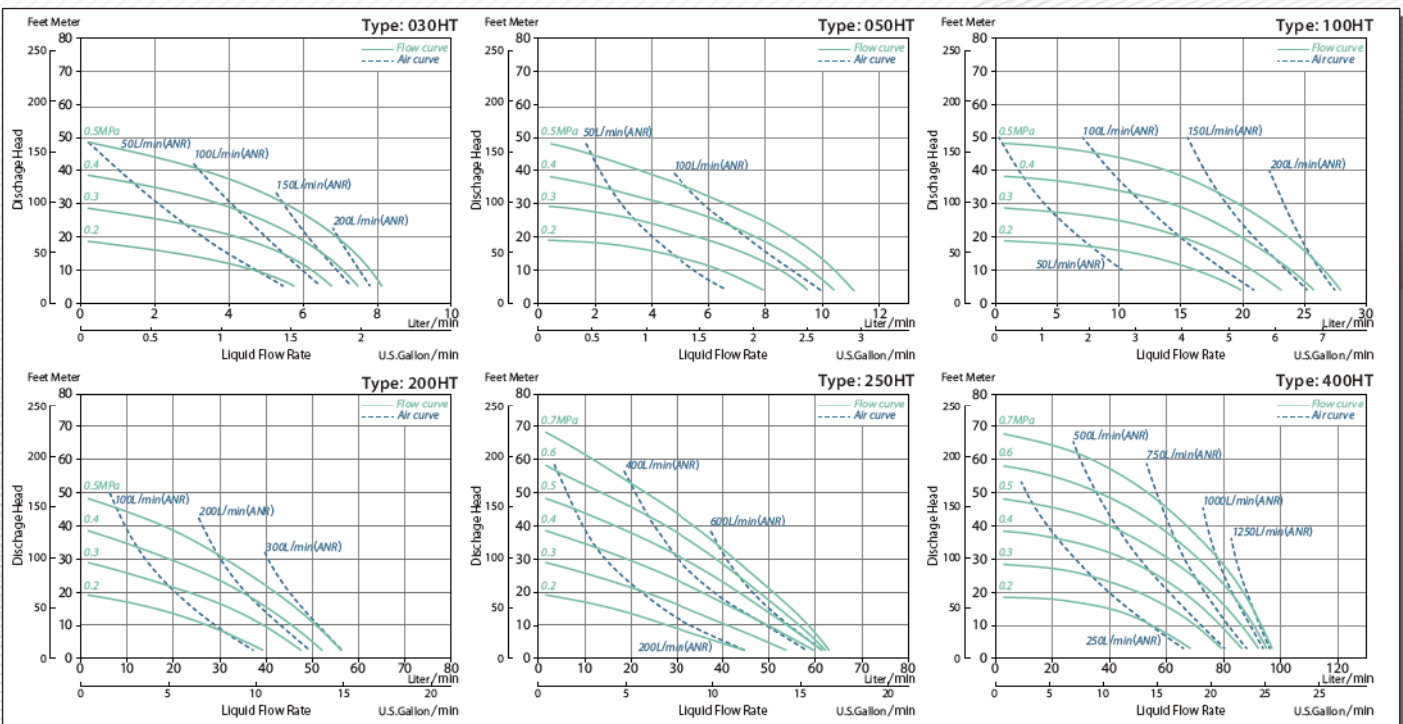

Flap Valve Solids Transfer Pump Models

Diaphragm Pumps with 2" Connections
Up to 600 L/min Max Flow rate.



Some Models

New 2" Flap Valve Solids Transfer Pumps for the Transfer of Large Solid Laden Liquids Up to 40mm in size.

Typically operated in water evacuation, process and waste type applications, Flap Valve Pumps utilize a reversed top down liquid flow path and with 4 large heavy duty flap valves to facilitate to transfer of liquids containing large sized solids. For ease of use & ease of maintenance, each pump is fitted with 4 externally accessible inspection panels allowing for each individual Flap Valve to be inspected cleaned or replaced simply and easily without having to remove the pump for service. This special externally accessible design also allows for the inspection & cleaning of the pumps diaphragms and other moving parts.

Fitted with the heavy duty Mechanical Coil-Spring Air Motor, each pump is designed for high performance operation, extreme reliability & extended parts life expectancy. They can operate anywhere from very low to very high air pressures with extremely efficient air consumption ratings. These pumps are particularly suited to frequent start stop, Dead Head & high backpressure type applications and can easily handle High Heads & very Long Discharge Lines.



D500A□JW-M

Flap Valve Solids Transfer Pump		
Model Code		500 A □ W
Max Flow Rate		600 L/min
Connection Type		Flange
Connections size	Air Supply	3/4"
	Air Exhaust	3/4" ※2 Ports
	Liquid	50A ※Center Port
Check Valve Type		Flap
Max Solid Size		Spherical Shape : Φ30mm or less Stick Shape : Φ15mm×45mm or less
Supply Air Pressure Range		0.1 ~ 0.7MPa
Materials	Wetted Body	Aluminium
	Air Motor	Aluminium
	Diaphragm	NBR, TPO

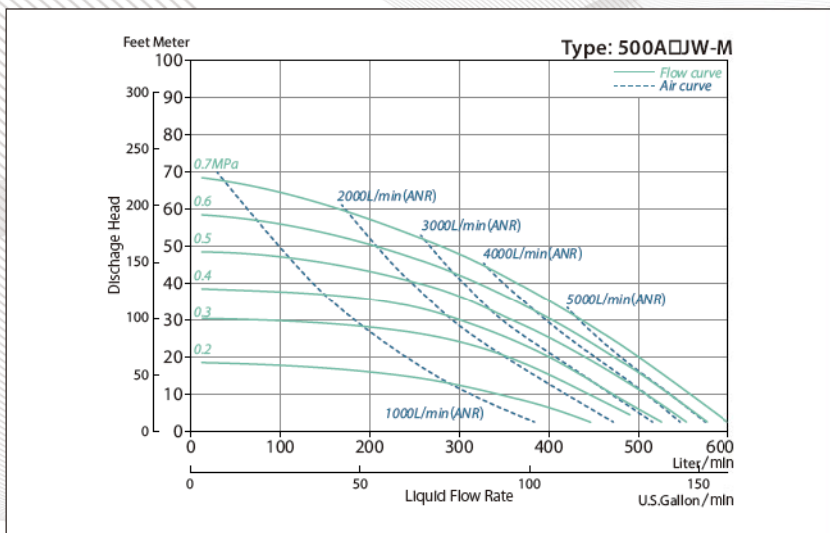
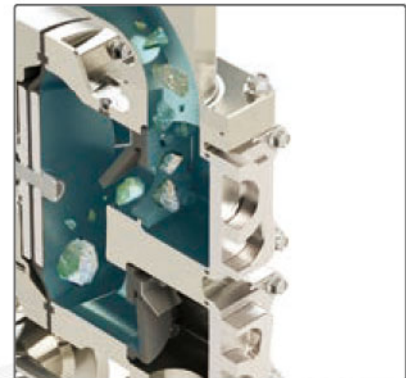

Externally Accessible Flap Valves.

Special outside accessible design.
Inspect, Clean and Service in Place.
Maintain Inline.
No need to pull the pump from service.

NEW Clamped Pump Models

Diaphragm Pumps with Ferrule Connections
Up to 330 L/min Max Flow rate.



New Clamped Pumps for Sanitary Applications are now available.

Clamp mounting structure enables pump to be easily serviced. All clamps used in these pumps are a 3-segment clamp for smooth tightening. The metal-to-metal contact is avoided and hence no metal sludge is generated from the pump, allowing the pump to be used in various industries.

The valve section uses an eccentric mechanism enabling valve to offset its position by rotating it even if the pump is slightly deformed due to the excess use of diaphragms, maintaining a high sealability for leakage prevention. High Performance looped C air spool can be accessed and replaced from the outside which makes the pump more convenient for maintenance.



D250STFR-A



D500STFR

Clamped Pumps			
Model Code		250 STFR-A	500 STFR
Max Flow Rate		180 L/min	330 L/min
Connection Type		Ferrule	
Connections size	Air Supply	3/8"	3/4"
	Air Exhaust	3/4"	1"
	Liquid	ISO 1.5s ≡ 3A 1 1/2"	ISO 2.0s ≡ 3A 2"
Check Valve Type		Ball	
Max Solid Size		3mm or less	8mm or less
Supply Air Pressure Range		0.2 ~ 0.7MPa	
Materials	Wetted Body	SUS316	SUS316L
	Air Motor	Nickel Plated Aluminum	
	Diaphragm	PTFE, EPDM	

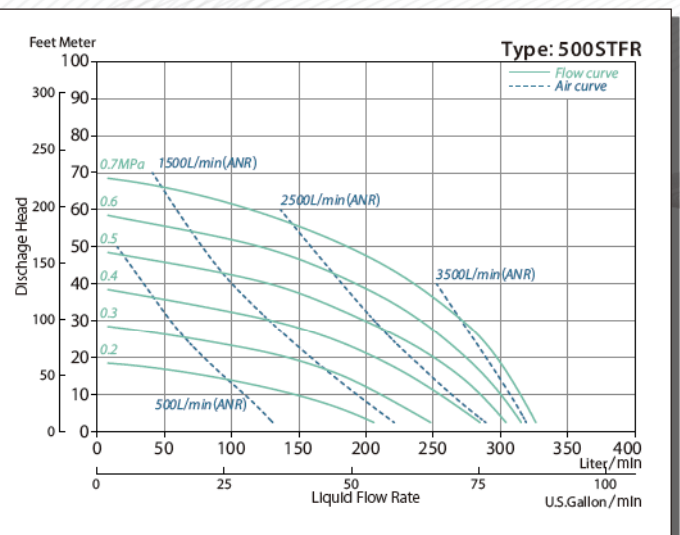
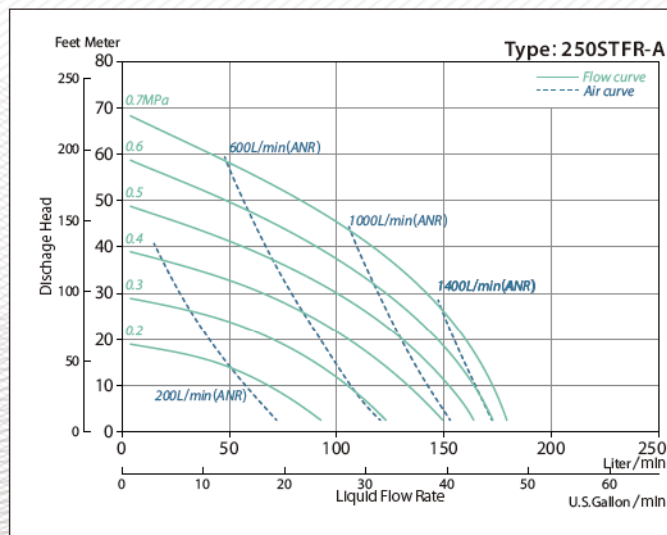

Specialty Pump Models

Drum Pumps

Air Powered Drum Syphon Double Diaphragm Pumps available in a wide range of sizes and materials. Suitable for pumping directly from 200 litre Barrels.

For the safe clean and efficient transfer of all kinds of liquids including corrosive chemicals, oils, lubricants, waste liquids, solvents and fuels. Can be used to pump flammable liquids and in explosive environments. Available with 1/4" 3/8" 1/2" 3/4" and 1" Liquid connections. Available Materials: PP, PPG, CFPP, CFPVDF, PTFE, CFPTFE, Aluminium, SUS, FDA & Electro Polished SUS. Max Flow Rate: 220 L/min. Max Slurry Size: 6.5mm on a 1" pump.



Drum Bung Pipe Adapter (SUS)



E Series Pumps

Compressed air powered AODD pumps with an electrically actuated air switching mechanism. E Series electric double diaphragm pumps used in critical process type applications and can be fully integrated into control systems and process machinery while still offering all the major benefits of an AODD pump.

Can be connected to our controller PC-124, has batching control system by strokes and / or time, remote control, and dry-run detection systems as its standard function. The controller can be linked with the leak sensor and the alarming system.

E series pumps are extremely reliable under all the operating conditions. It utilizes electric solenoid actuation and stroke sensor for full pump controllability.

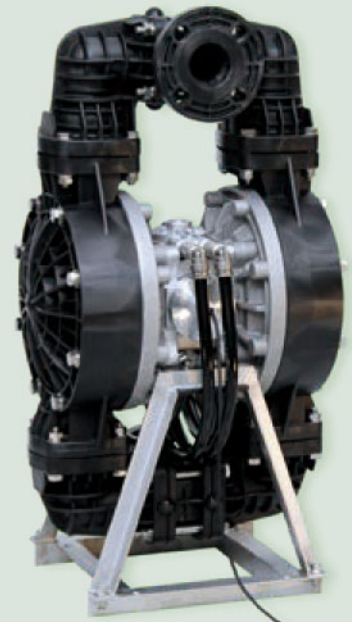

D400V□J-EX
1 1/2" CFPVDF E Type Pump (Flanged)
350 L/min Max Flow Rate



PC-124



D050HT-EX
1/4" PTFE E Type Pump
13 L/min Max Flow Rate

Specialty Pump Models

Conductive Polypropylene Pumps



Electrically Conductive Polypropylene Double Diaphragm Pumps used for the safe transfer of flammable chemicals or for use in explosive environments.

Carbon filled Polypropylene used to manufacture all major body components including both the Liquid and Air Side on the pump. Available in sizes 1/4" to 2" connections. Offering high Chemical Resistance and a fully Bolted Design with inbuilt engineering features designed to resist material creep so reducing the chance of leaks forming over time.



D050CT-X
1/4" Carbon PP Pump
11.5 L/min Max Flow Rate



D101C-X
3/8" Carbon PP Pump
22L/min Max Flow Rate



D152C-X
1/2" Carbon PP Pump
62 L/min Max Flow Rate



D250C-X
1" Carbon PP Pump (Flanged)
180 L/min Max Flow Rate



D400C-X
1 1/2" Carbon PP Pump
380 L/min Max Flow Rate

Powder Transfer Pumps

Specially Designed Powder Pumps to syphon and transfer very fine, dry, bulk powders effectively throughout a process and help create a safe, efficient and dust free environment. Powder Transfer Pumps can eliminate the need for intensive manual labour, heavy lifting or mechanical Augers & Conveyors.

To operate correctly, the Powder must be completely dry and free flowing. Typically powders such as Pigments, Activated Carbon, Powder Coatings, Carbon Black, Fumed Silica, Talc, Toners & Powdered Plastics can all be transferred successfully. Transferring distance will depend entirely on the type of powder, its weight, size, shape and bulk density. However it is always recommended that a trial is firstly carried out to determine the pump-ability of a certain type of powder.

Powder Pumps are available in the following Sizes & Materials

3/4" 1" 1 1/2" 2" & 3" Aluminium or Stainless Steel. Shipped with factory fitted Compressed Air Induction System. The standard model utilizes 4 inlets however custom models are available. Many more options and accessories are also available. # please consult YTS for more information about pumping powders and Powder Pumps.

Compressed Air Induction System.

Powder Pumps are fitted with an Air Induction System to fluidize the powder and help stop clumping and sticking. Pre Fluidization before operating the pump will also help reduce the chance of pump damage caused by settled and compacted powders.



D250A-X
1" Powder Pump.



D500A-X
2" Flanged Powder Pump.

Specialty Pump Models

High Pressure Pumps

High Pressure Double Diaphragm Pumps for applications where high liquid discharge pressures are required to overcome system requirements.

Often utilized in filter press type applications and can easily handle High Heads, very Long Discharge Lines and Frequent Dead Head type processes. Pressure output is roughly doubled however the flow rate is roughly halved. 2:1 discharge pressure ratio is achieved by utilizing twice the surface area (driving both diaphragms) to double the discharge pressure output. High Pressure 2:1 pumps are available with ¾" 1" 1½" 2" & 3" connections with aluminium, stainless steel and cast iron construction.

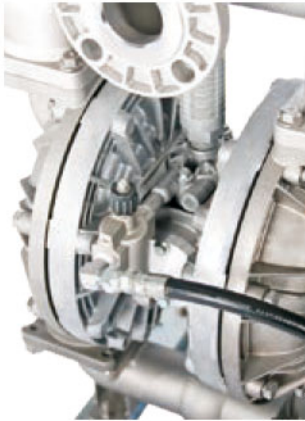

D500S□J-MX
2" High Pressure SUS Pump
375 L/min Max Flow Rate

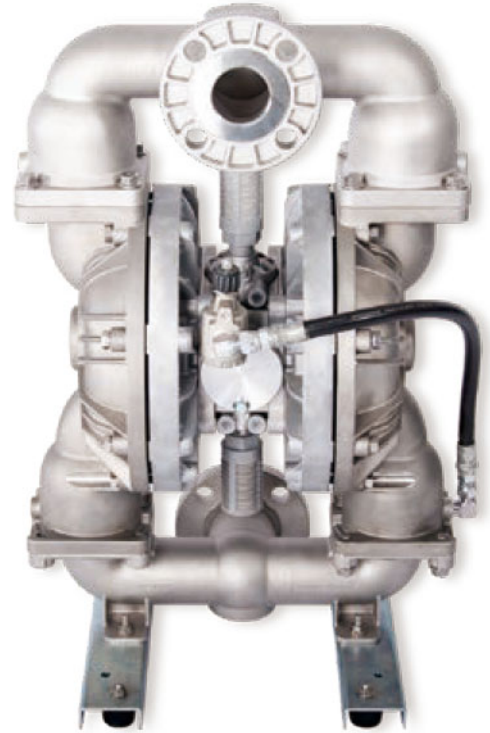

FDA Grade Sanitary Diaphragm Pumps

FDA Grade Sanitary Double Diaphragm Pumps for Food, Beverage, Pharmaceutical, Cosmetics & Chemical applications where 3A, USDA or EHEDG standards are not required.

Available in all sizes ¼" to 3" in Stainless Steel. Manufactured from FDA & Halal Compliant Materials. 316 Electro Polished Stainless Steel Housings & Hardware with Oversized Sanitary Flange Connections Welded Directly to the Pump. Electro Polished Inside and Out.

ISO Type Sanitary Flanges Shipped as Standard. Optional 3A Type Connections are Also Available.

FDA Compliant Drum Pumps & FDA Pulsation Dampeners are also available.



D250S□F-X
FDA Type Electro Polished HD SUS Pump.
1½" Sanitary Flange Connections.
190 L/min Max Flow Rate. (PTFE Diaphragms)
6.5mm Max Solids Size.



D500S□F-MX
FDA Type Electro Polished SUS Pump.
2½" Sanitary Flange Connections.
520 L/min Max Flow Rate. (PTFE Diaphragms)
8mm Max Solids Size.



Sanitary Flange Connections

Shipped as standard on all FDA compliant pumps. Welded and Oversized Stainless Steel. Available in either Standard ISO or optional 3A sizes.

Suitable Sanitary Type Clamp fittings and gaskets sold separately

Pump Dimensional Drawings

Type 030 / 050

030V ... 1.7Kg
 050P ... 1.4Kg
 050V ... 1.7Kg () 030V, 050V

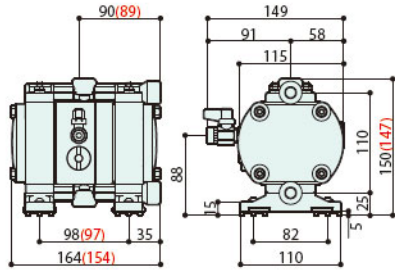

050A ... 1.7Kg
 050S ... 2.7Kg

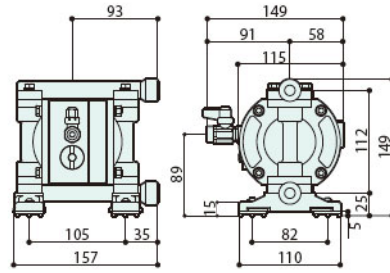

Type 031 / 051

Unit = mm

031V ... 1.5Kg
 051P ... 1.2Kg
 051V ... 1.5Kg () 031V, 051V

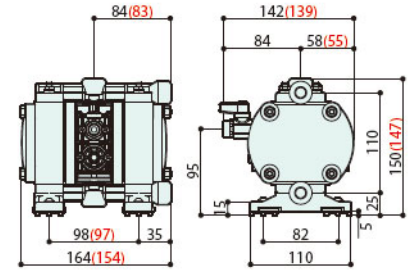

Type 101

051A ... 1.5Kg
 051S ... 2.5Kg

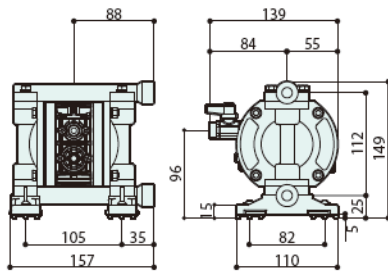

101P ... 2.9Kg

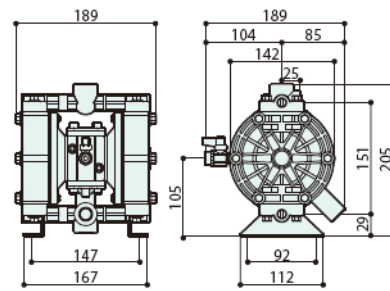

101A ... 3.4Kg
 101S ... 5.1Kg () 101S

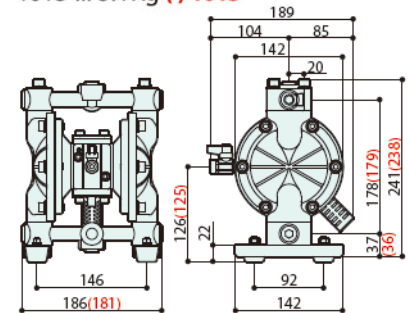

Type 152

152P ... 3.2Kg
 152V ... 4.2Kg

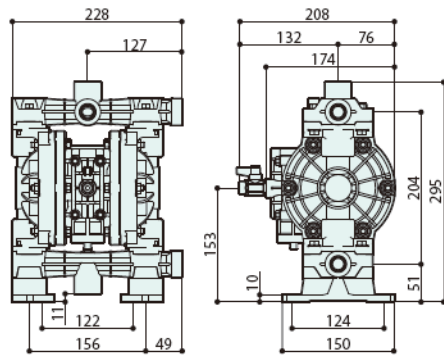

152A ... 4.2Kg
 152S ... 6.7Kg

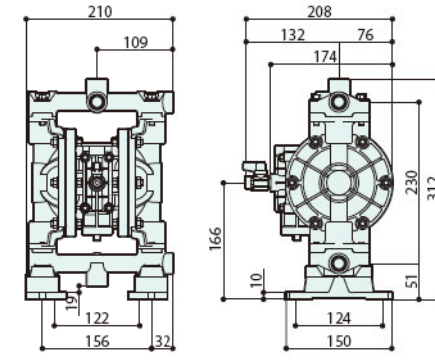

Type 200

200G ... 6.8Kg

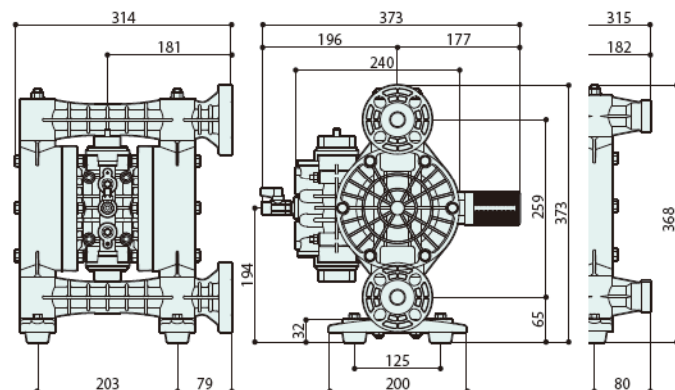

200A ... 10.5Kg
 200S ... 18.5Kg () 200S

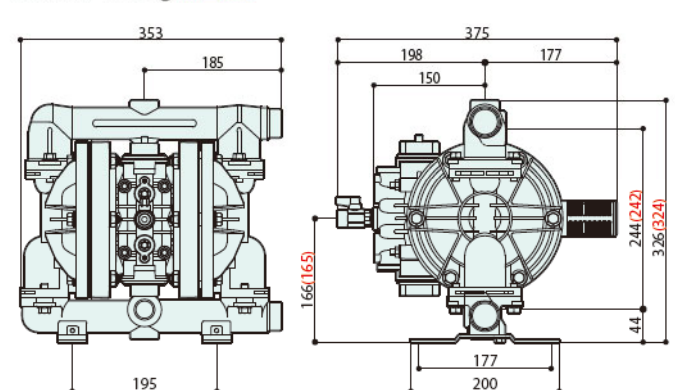

Pump Dimensional Drawings

Type 200

200A-A ... 11.5Kg
200S-A ... 20.0Kg () **200S-A**

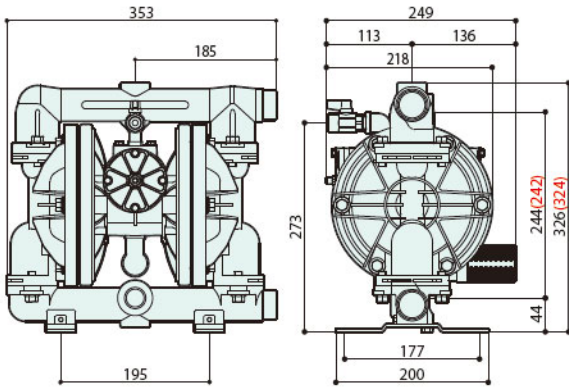

250A ... 10.5Kg
250S ... 19.0Kg

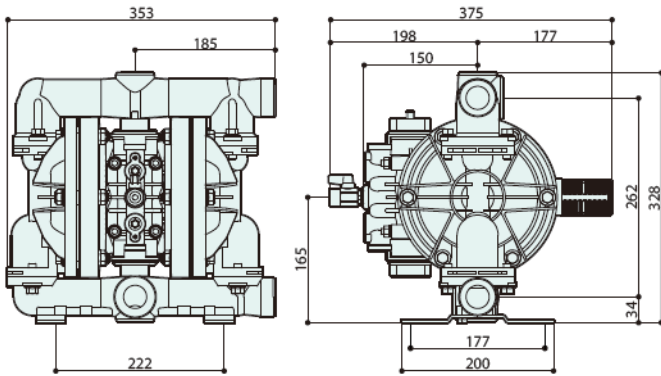

Type 250

250G ... 10.0Kg
250V ... 12.5Kg () **250V**

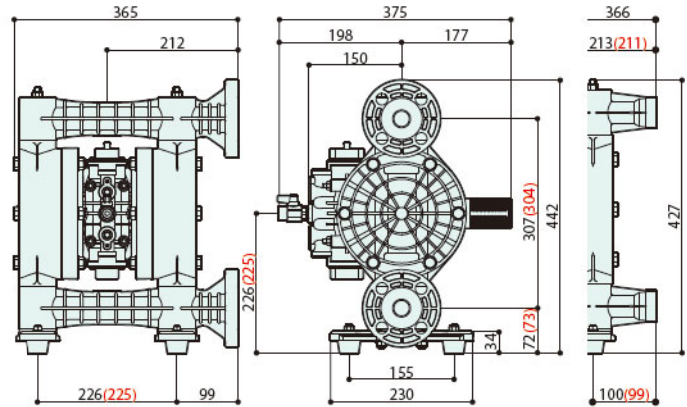

250A-A ... 12.0Kg
250S-A ... 20.5Kg

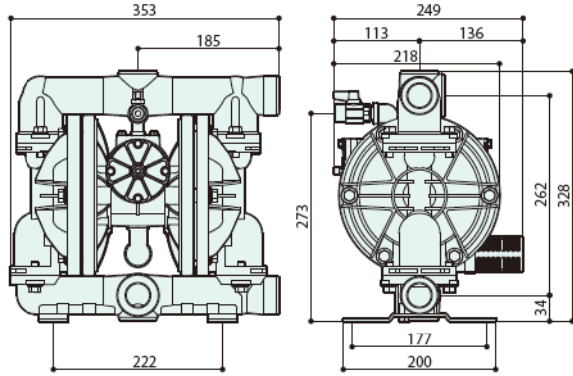

Type 400

400G ... 29.0Kg
400V ... 32.5Kg () **400V**

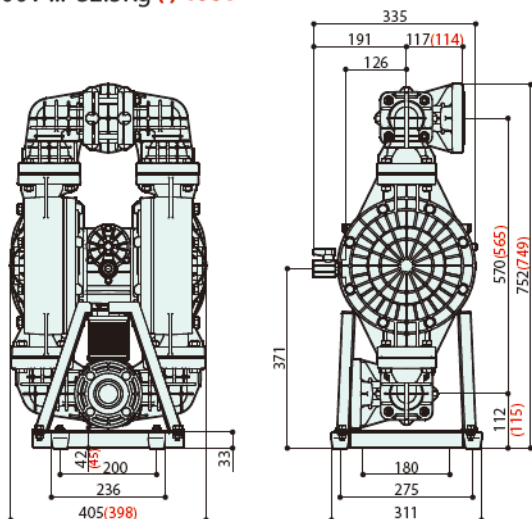

400A ... 30.0Kg
400S ... 55.0Kg

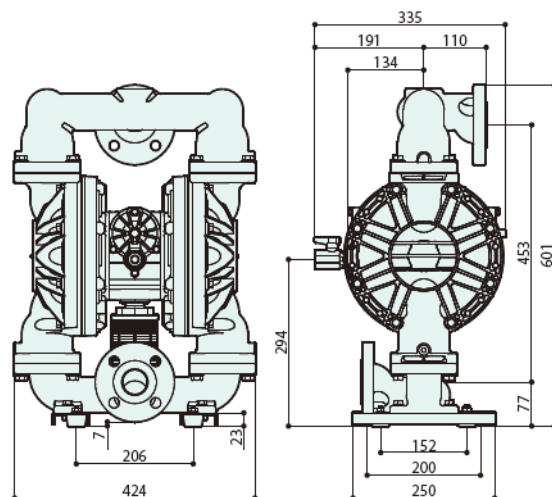

Unit = mm

Thread

Pump Dimensional Drawings

Unit = mm

Type 400-M

400G-M ... 28.5Kg
400V-M ... 34.5Kg () **400V-M**

400A-M ... 31.5Kg
400S-M ... 55.0Kg

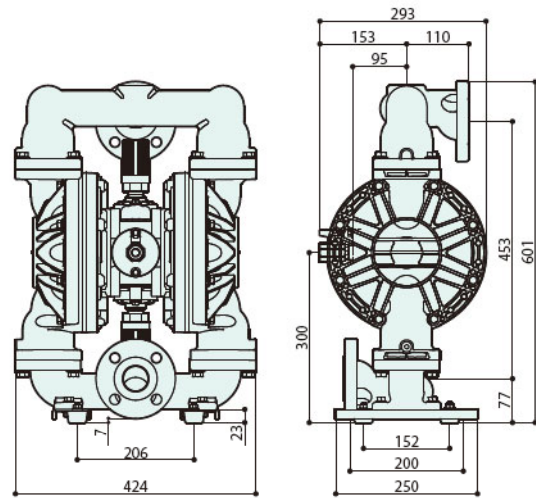
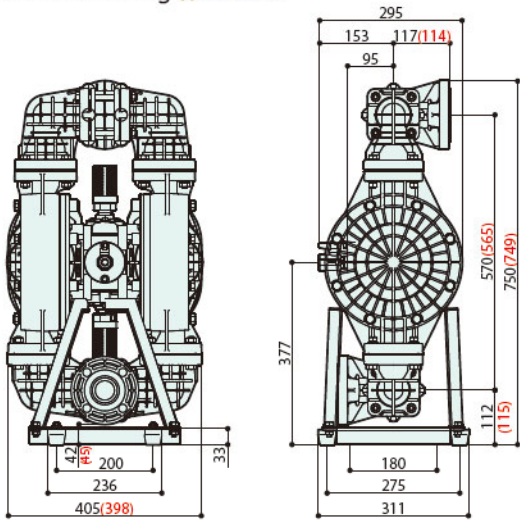

Type 500

500G ... 37.5Kg
500V ... 44.5Kg () **500V**

500A ... 39.4Kg
500S ... 69.0Kg () **500S**

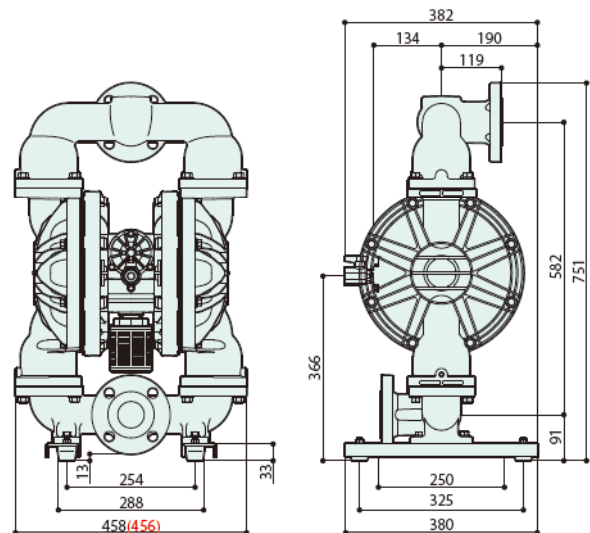
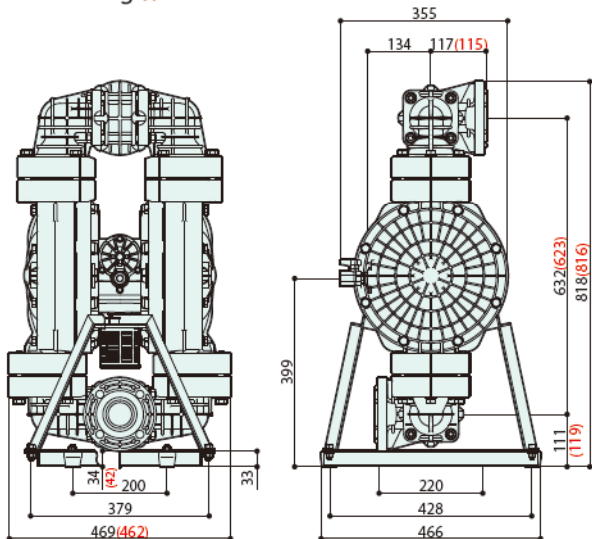

Type 500-M

500G-M ... 38.0Kg
500V-M ... 45.0Kg () **500V-M**

500A-M ... 40.0Kg
500S-M ... 69.5Kg () **500S-M**

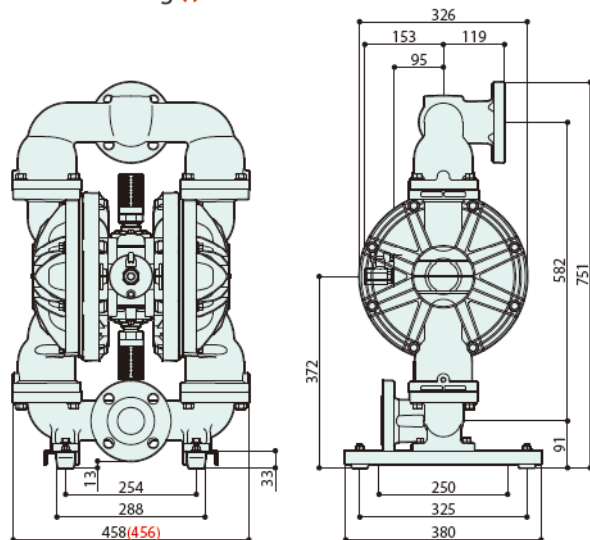
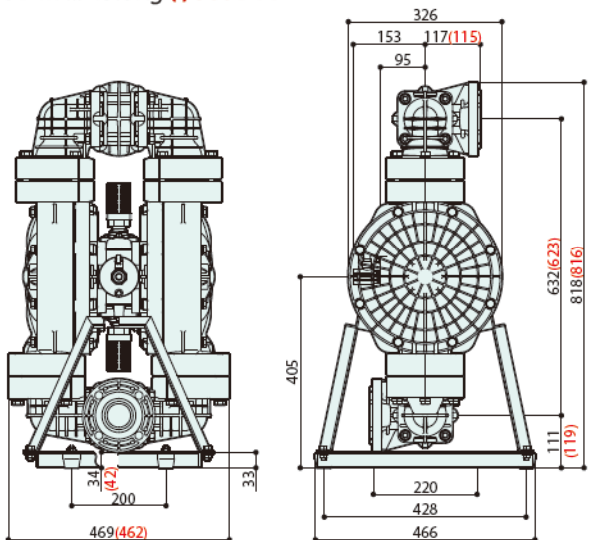

Pump Dimensional Drawings

Unit = mm

Type 800

800G ... 70.0Kg

800A ... 68.5Kg

800S ... 144.5Kg

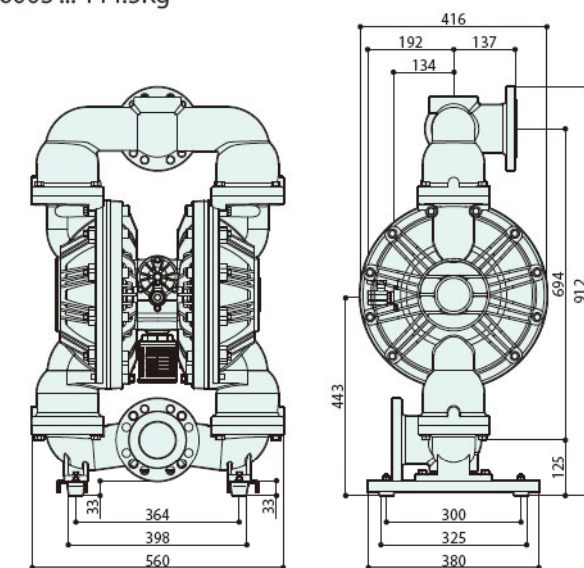
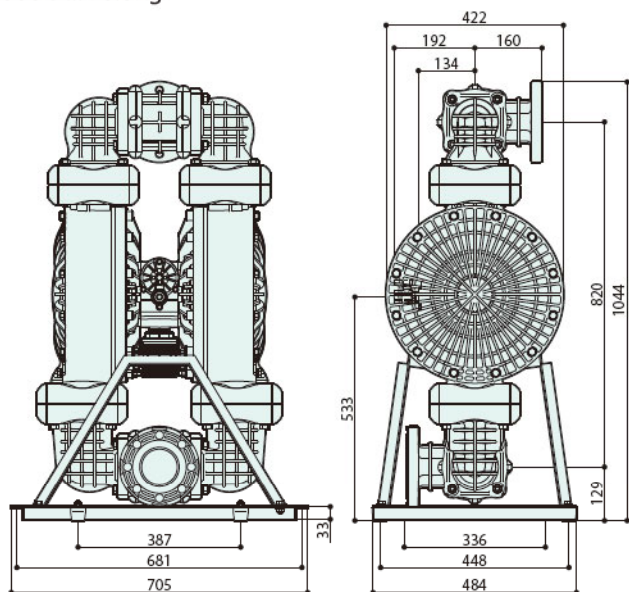

Type 800-M

800G-M ... 70.0Kg

800A-M ... 69.0Kg

800S-M ... 140.5Kg

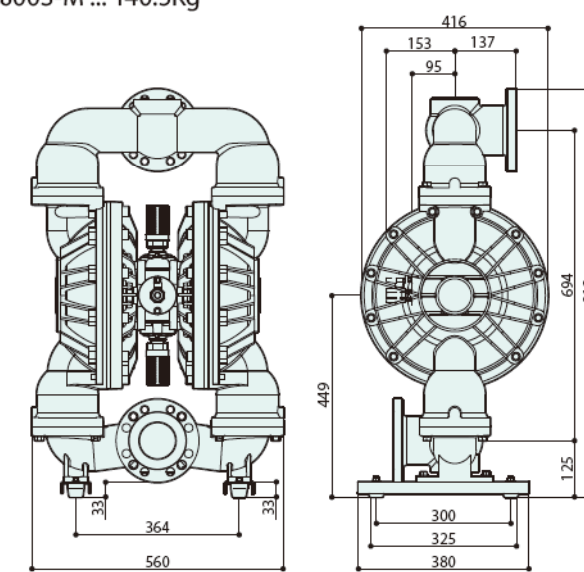
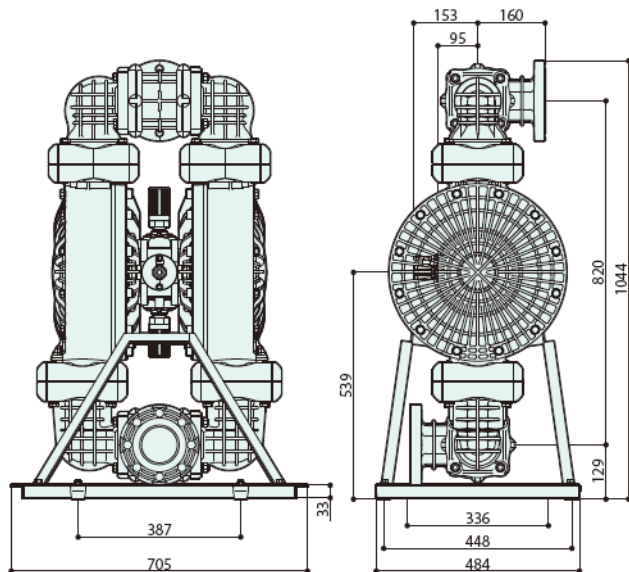

Standard PTFE Pumps

031TT ... 3.0Kg

051TT ... 3.0Kg

152TT ... 11.5Kg

250TT ... 31.0Kg

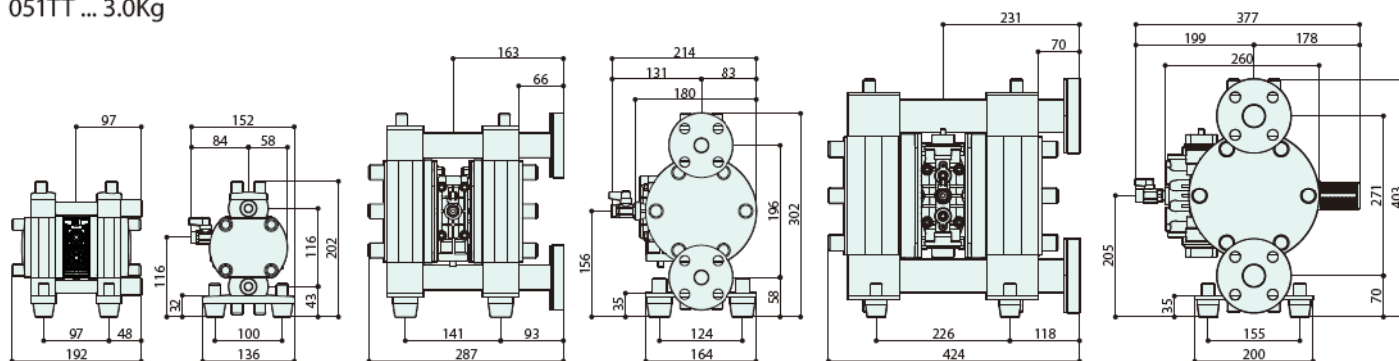

Pump Dimensional Drawings

Unit = mm

High Purity PTFE Pumps

030HT ... 3.4Kg
050HT ... 3.4Kg

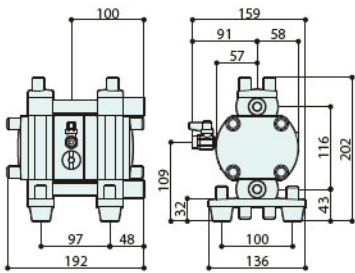

100HT ... 7.4Kg () Thread ... 7.0Kg

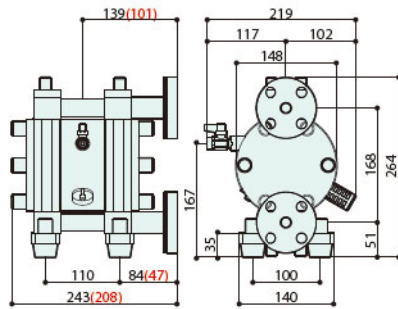

200HT ... 15.0Kg () Thread ... 14.0Kg

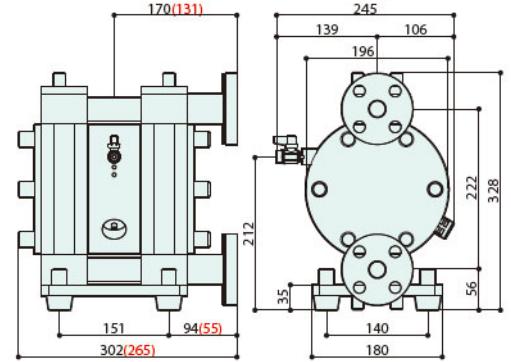

250HT ... 32.0Kg

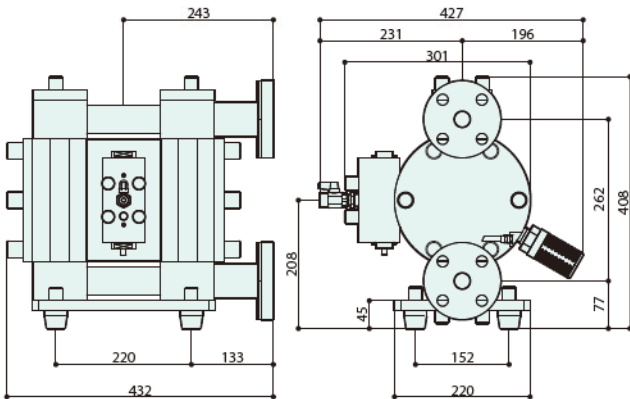

400HT ... 53.0Kg

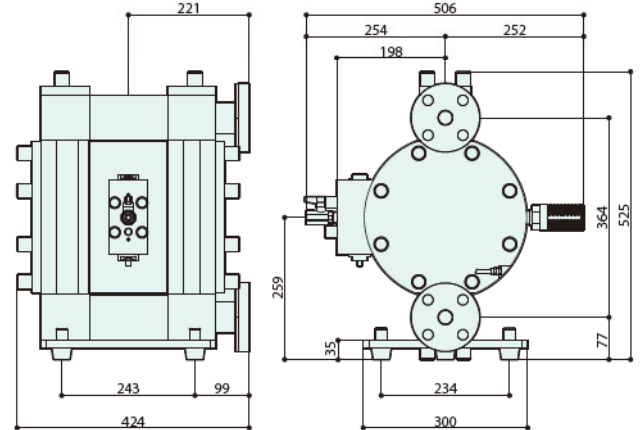

Clamped Pumps

250STFR-A ... 19.5kg

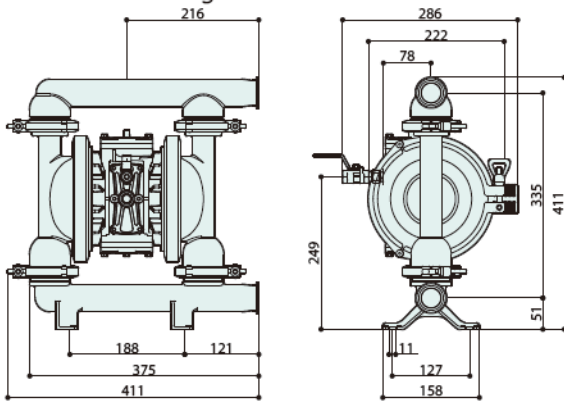

500STFR ... 41.0kg

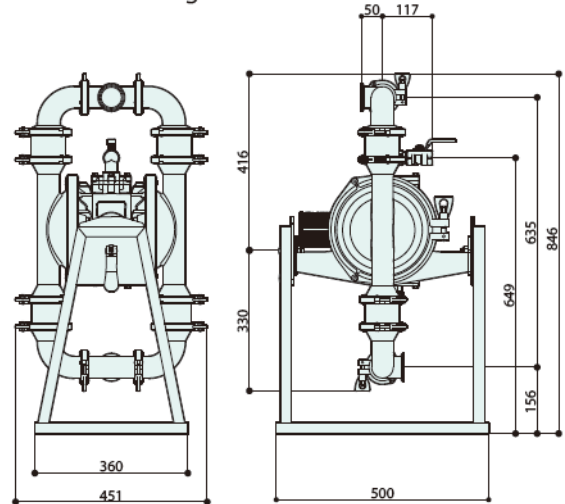

Flap Valve Solids Transfer Pumps

500AW ... 55.5Kg

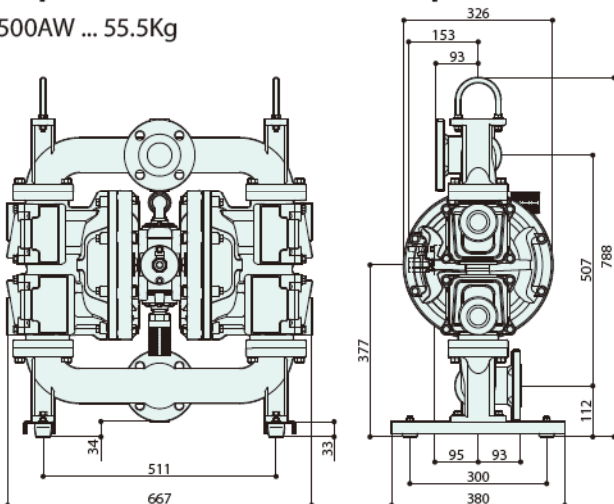

Common Accessories & Options

Liquid Pulsation Dampeners

A comprehensive range of high Performance Liquid Pulsation Dampeners in various sizes and Materials. Reduce Liquid Pulsation by up to 95%.



Pulsation Surge Tanks

Cost effective & convenient method of suppressing liquid pulsation. Able to transfer liquid slurries and large solids without decreasing flow rates. Available in SUS316 with threaded connections for 3/8", 1/2" and 1" metallic pumps.



Air Filter Regulators

Built in moisture and particulate removal of up to 5 micron. Analogue type pressure gauge with locking function. Manual drain system. Provides optimal pump control and helps improve compressed air efficiency.



Specialty Diaphragm Options

A full range of high performance Pump Diaphragms available in all sizes and materials. Optional TPO rubber Back up Diaphragms. One Up® Brand Specialty Diaphragms. Bonded Rubber PTFE Diaphragms. New One piece solid type PTFE diaphragms are also available.

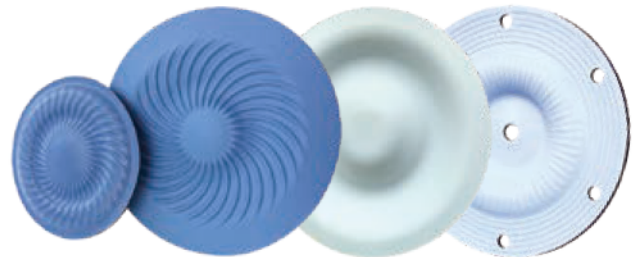

Stroke Counter Option

Pneumatically actuated mechanical stroke counter. Non electrical. Fitted to the pump via an air hose. Used for measuring stroke life of pump or diaphragms. Can be used to measure and calculate liquid volume over time.



PTFE Coatings

PTFE Coated Air motor Assembly for increased chemical resistance. Used to protect air motor assembly from ruptured Diaphragms, chemical spills or for use in corrosive environments.



Common Accessories & Options

Automatic Liquid Level Controller

The HLC Automatic Liquid Level Controller is a pneumatically controlled system designed to automatically start and stop an AODD Pump when the liquid level within a tank reaches a predetermined Hi or Low level.

The HLC is available in 4 different models.



Anti-Stall Accessories

Variety of accessories to solve stall problems are available.



Conductive Liquid Leak Sensor Kit

Automatically detect leaks or diaphragm ruptures. Automatically cuts air supply, triggers cut of valves or sounds warning alarms etc.



Check Ball Valve & Seat Options

The materials of the check ball valves and seats can be changed for specific applications when transferring fluids that have a high specific gravity, are highly viscous and / or when increased chemical resistance is required.



Tools

A full range of standard & specialty pump service tools are available for all model pumps.



Spare Parts & Pump Service Kits

A full Range of Spare Parts and Pump Service Kits are available for all new and old model pumps.



Fully Engineered Diaphragm Pumps

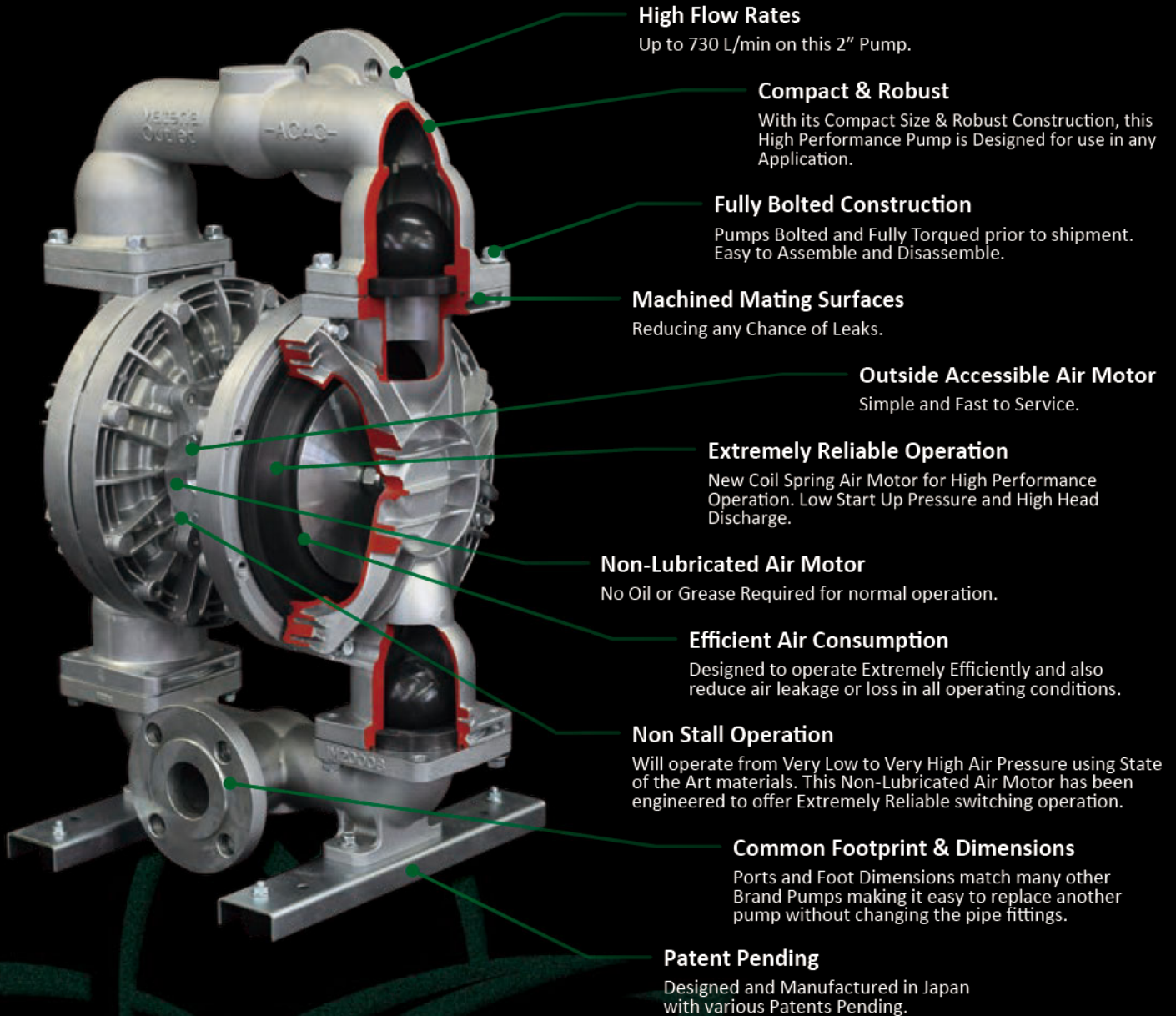

High Flow Rates

Up to 730 L/min on this 2" Pump.

Compact & Robust

With its Compact Size & Robust Construction, this High Performance Pump is Designed for use in any Application.

Fully Bolted Construction

Pumps Bolted and Fully Torqued prior to shipment. Easy to Assemble and Disassemble.

Machined Mating Surfaces

Reducing any Chance of Leaks.

Outside Accessible Air Motor

Simple and Fast to Service.

Extremely Reliable Operation

New Coil Spring Air Motor for High Performance Operation. Low Start Up Pressure and High Head Discharge.

Non-Lubricated Air Motor

No Oil or Grease Required for normal operation.

Efficient Air Consumption

Designed to operate Extremely Efficiently and also reduce air leakage or loss in all operating conditions.

Non Stall Operation

Will operate from Very Low to Very High Air Pressure using State of the Art materials. This Non-Lubricated Air Motor has been engineered to offer Extremely Reliable switching operation.

Common Footprint & Dimensions

Ports and Foot Dimensions match many other Brand Pumps making it easy to replace another pump without changing the pipe fittings.

Patent Pending

Designed and Manufactured in Japan with various Patents Pending.



Looped C[®] Air Spool.

New Generation
Mechanically Assisted
Non-Centering Spool

100% Non-Lubricated.
Increased Performance.
Improved Reliability.
Extended Life expectancy.
Outside Accessible.
Modern Materials of Construction.
Common "Drop-in" sizes.



Mechanical Air Spool.

3rd Generation Heavy Duty
Mechanically Assisted Non-Centering
Air Spool

For tough & demanding applications.
Will resist spool stalling & freezing in nearly all operating conditions.
Superior pumping performance.
Extreme reliability.
Serviceability & Longevity.
100% Non-Lubricated.
Outside Accessible.

YTS Pump Model Code Nomenclature

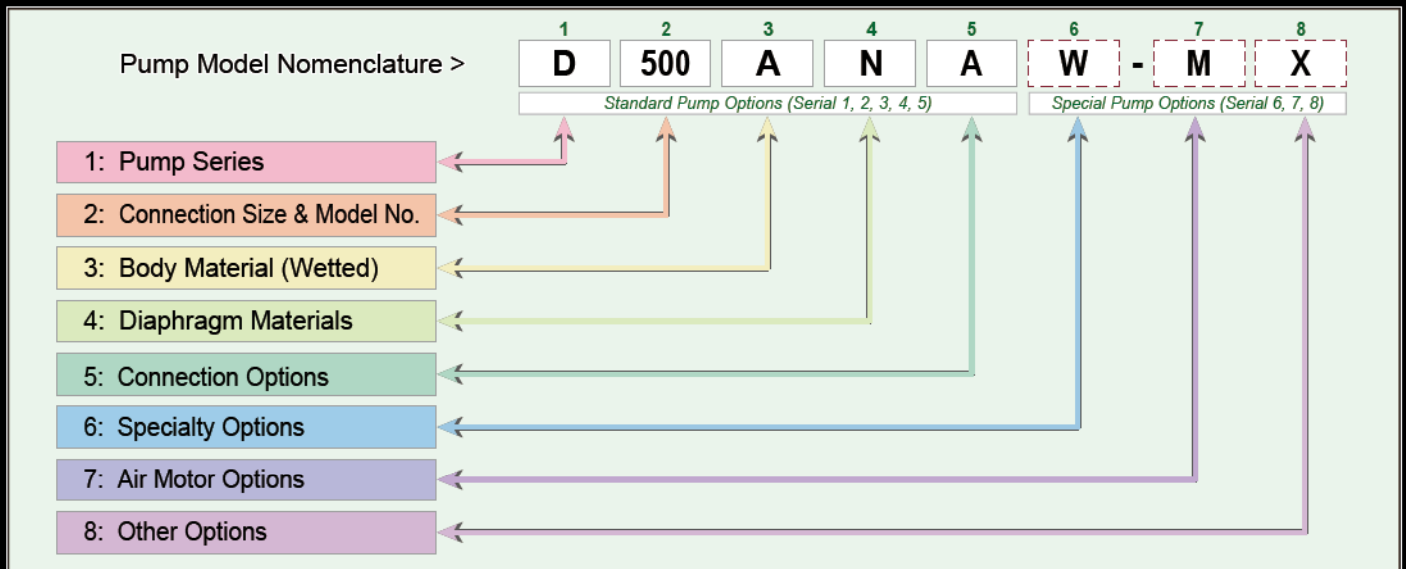

1: Pump Series D: Standard Pump Series	2: Connection Size & Model No. 030 = 5mm (1/4") 031 = 5mm (1/4") 050 = 5mm (1/4") 051 = 5mm (1/4") 101 = 10mm (3/8") 152 = 15mm (1/2") 200 = 20mm (3/4") 250 = 25mm (1") 400 = 40mm (1 1/2") 500 = 50mm (2") 800 = 80mm (3") 100 = 10mm (3/8") 150 = 15mm (1/2") 151 = 15mm (1/2")	3: Body Material (Wetted) A: Al (Aluminium) S: SUS (Stainless Steel) G: PPG (Glass Filled PP) P: PP (Pure Polypropylene) V: PVDF (Polyvinylidene Fluoride "KYNAR") T: PTFE (Fluoroplastics) H: High Purity PTFE (Fluoroplastics) D: POM (Polyoxymethylene) F: Fe (Cast Iron) C: CF PP (Conductive Polypropylene) E: CF PTFE (Conductive Fluoroplastics)
---	---	--

4: Diaphragm Materials C: Neoprene™ (CR) E: Nordel™ (EPDM) N: Buna N (NBR) H: Hytrel™ (TPE / TPEE) S: Santoprene® (TPO) V: Viton® (FPM / FKM) T: PTFE	5: Connection Options <input type="checkbox"/> PT, Rc, BSPT N: NPT J: PT Air Supply, JIS / DIN Flange * A: NPT Air Supply, ANSI Flange * F: Ferrule (ISO/3A) T: Tube <small>*Type 400, 500 and 800 metallic pumps come with threaded flange manifolds.</small>	6: Specialty Options <input type="checkbox"/> Standard Pump W: Flap Valve Pump R: Clamped Pump
--	---	--

7: Air Motor Options <input type="checkbox"/> Spool Valve M: Mechanical Coil Spring A: Spool Valve with Aluminium Body (200 & 250 series only) E: Electrical Type	8: Other Options X: Other Options Other than standard pumps TPO Backup Diaphragm, One-Up® PTFE Diaphragm, PTFE Ball Check Valves, PTFE Check Seats, SUS Ball Check Valves, SUS Check Seats, FDA Compliant Pump, 1 1/2" Center Ports (250 metallic pump) Leak Sensor, Stroke Counter, High Pressure 2:1 Pump, Powder Pump, Split Manifold Pump and more...
---	--

The red characters above are non-standard products.

Notes: ONE-UP® is a registered trademark of Garlock®. Hytrel® is a trademark of E.I. du Pont de Nemours and Company. Kynar® is a registered trademark of Arkema. Nordel™ is a trademark of DuPont Dow Elastomers. Ryton® is a trademark of Chevron Phillips Chemical Company. Santoprene® is a registered trademark of Monsanto Co. Viton® is a registered trademark of DuPont Performance Elastomers.

Notes: Options, Variations, Add On's and Accessories may not be available for all models sizes or materials. YTS stocks a full range of Pumps Parts and Accessories (Standard Stocked Items). Other models are classified as Order-only and stock may not be available. For information about the Line Up, Prices, Availability and Delivery please contact YTS or your Pump Distributor directly.

Note: factors affecting a pumps stated liquid flow rate, suction lift & solids handling capabilities include but are not limited to; pump size, diaphragm, ball valve & ball seat, type & materials of construction, air inlet pressure & air flow capability, liquid viscosity, specific gravity, slurry content, ambient & liquid temperature, liquid inlet & liquid outlet width, piping type, piping length & overall piping configuration.



Notes:

Products & specifications contained within this catalogue may be changed without notice. Pumps listed are available in various and materials. For each application please take extreme care with pump choice and always consider factors such as chemical compatibility, solids size, abrasion resistance, temperature of the liquid, temperature of the surrounding atmosphere, airline or liquid line pressure etc. Always refer to MSDS and chemical compatibility charts or for more information about chemical compatibility. For more information on choosing the correct pump, please consult with your distributor or contact YTS directly. Note that products contained may be subject to international trade restrictions or embargoes and may require an export permit from the Japan Ministry of Economy and Industry (METI) prior to dispatch. For more information regarding international export control regulations please contact your distributor or YTS directly. For information regarding re-export please contact your local authorities directly. For information regarding CE & ATEX refer to the CE and ATEX certification available separately. Countries where YTS patents were applied : Japan, China, Korea, USA, Italy, Denmark, France, Germany, Netherlands, Sweden, and England.

Manufacturer : YTS JAPAN Co.,Ltd.

Address : 598-10, Monoi, Yotsukaido City,
Chiba 284-0012, Japan

Phone : +81 (0)43 310 6606

F a x : +81 (0)43 424 8977

E - mail : sales@yts-pump.com

Web Site : yts-pump.com



Subsidiary : YTS Pump Engineering BV.

Address : Logistiekweg 26,
7007 CJ Doetinchem, the Netherlands

Phone : +31 (0) 85 760 7060

E - mail : info@yts-pumps.com

Distributor



*Please note, the products or specifications contained within this catalogue may be changed without notice.

Copyright © 2023.01 YTS JAPAN Co.,Ltd All rights reserved. No.0006